



## K Series

Controllers / mini-programmers  
with wattmeter function and independent timer

### USEFUL APPLICATIONS

- Shoemaking Machineries
- Glueing and binding machines (hot glue)
- Packaging and blister packing machines
- Paint booths
- T-shirt print
- Climatic chambers
- Hot runner
- Glass bending ovens
- Extruders
- Industrial baking or large kitchens
- Continuous multi-zone ovens (for PCB, for leather goods, etc.)
- Ceramics ovens
- Heat-treatment ovens
- Ovens for goldsmiths and dentists
- Simple cascade controls

- Input for TC, RTD, PTC, NTC, mA or V
- **User Calibration**
- H/C PID Control with overshoot control, self-tune and **2 Autotuning algorithms**
- **8 segment programmer function with segment recovery, 2 events** and stasis control (guaranteed soak)
- **Independent timer** with 4 functioning modes
- H/C On/OFF Control with compressor protection time
- **Wattmeter** for calculating the instantaneous power and energy used
- **Digital Retransmission** of the set point
- **Counter** for days and hours worked with programmable threshold for **preventative maintenance**
- Delay at the start up function
- **Parameter sequence freely programmable**
- Ramp to set point change
- RS485 Serial Communication with Modbus RTU protocol
- Soft start

## TWO AUTOTUNING ALGORITHMS

In order to meet the clients' needs and those of their production processes, TECNOLOGIC have developed two autotuning algorithms (as well as adaptive self-tuning): Oscillatory autotuning and the "fast" type.

**- Oscillatory autotuning** is the classic type that requires 3 oscillations to be made around a set point. This type of tuning is particularly accurate and can be set up at any moment. However, it takes a long time and generates an overshoot that, although not exaggerated, may not be appreciated.

**- Fast autotuning** on the other hand is much faster and therefore particularly suitable for very slow processes. Another of its characteristics is that it does not generate overshoot (the algorithm aims at keeping the PV under the set point). Finally fast autotuning, applied in multi-loop systems, feels the "dragging" effects produced by neighbouring loops much less and is therefore particularly suitable for machines such as extruders, hot-runners, continuous ovens, etc.

## USER CALIBRATION

This function allows the manufacturer of the machine **to calibrate the entire measuring chain** thus compensating for all errors due to:

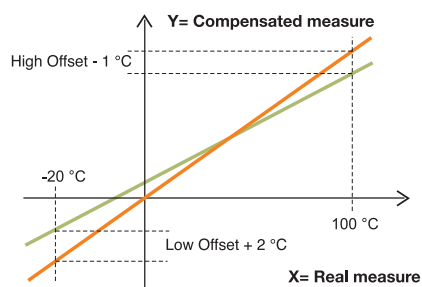

- sensor position
- class of sensor
- accuracy of the instrument.

The user calibration does NOT modify the plant calibration and can always be cancelled.

## DIGITAL RETRANSMISSION

By making use of serial communication and without using a PC, it is possible for an instrument (Master) to send its operative set points to other instruments (Slave).

Furthermore, each slave instrument can add one of its offsets to the value received.

It is therefore possible to modify the set point of all the connected instruments by modifying the set point of the master only.

Typical applications include continuous ovens, hot-runners, polymerization ovens, etc.

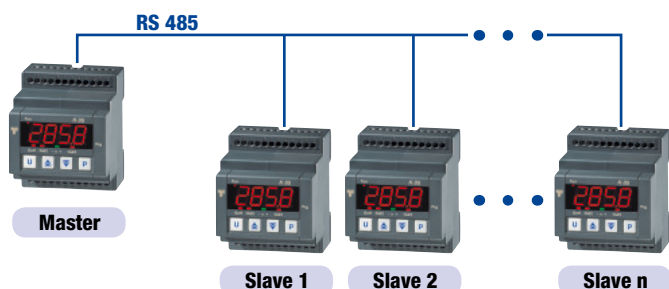

## PROGRAMMER FUNCTION

### Applied example:

**Paint booth and drying chamber for spray paints (spray booths for bodywork).**

- During the painting phase, the temperature inside the booth must remain at 20°C and the air used for its ventilation must come from outside.
- Once the painting is finished, the operator leaves the booth, closes the door and starts up the "drying" cycle.

During this phase the instrument closes the air gate and recycles the air inside the booth by means of which energy consumption is reduced.

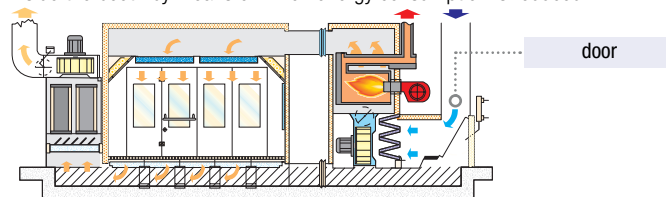

- When the drying phase is over but before the operator can enter the booth, it is necessary to re-open the air gate and ensure that:
  - 1) The air inside the booth has been replaced with air from outside.
  - 2) The temperature in the cabin is lower than the pre-established value.

The thermal profile needed is as follows.

Out 1 = Heating output

Out 2 = Event 1

Out 3 = Programme running

Event 1 = in ON during ramp 1, stasis 1, ramp 2, and stasis 2.

Once the programme is running the door stays blocked.

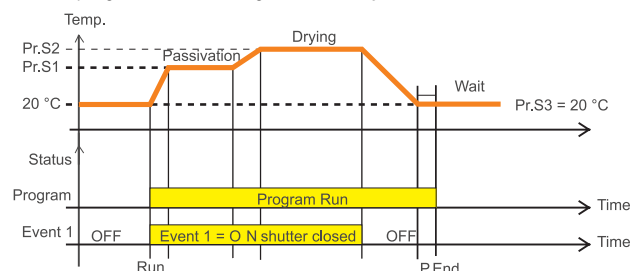

The control function of the stasis allows us to end the programme (therefore allowing access to the operator) ONLY when the temperature in the booth has reached the programmed value (in the example Pr.S3). In addition, if a power down occurs during program execution, at the next power up, the instrument is able to continue the program execution starting from the segment in progress and, if the segment was a soak, the restart point will take care of the soak time already made (with an accuracy equal to 30 min.)

## ACCESSORIES

### A01 - Programming key

Makes it possible to:

- Memorize the configuration of an instrument to transfer it to other instruments
- Transfer a configuration to a PC
- Memorize a configuration recorded in a PC
- Let the instrument "converse" directly with a PC.



### WinTec - Supervisor

- Data Acquisition
- Supervision
- Alarm management
- Recipe management
- Trend
- Reports.

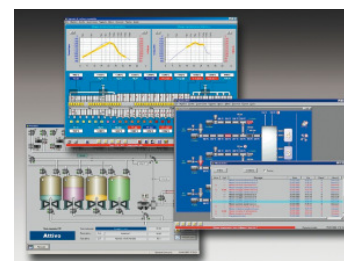

## TECHNICAL FEATURES

### ELECTRICAL DATA

**Power supply:** see the "How to order"

**Power consumption:** max 6 VA

**Device Class:** Class II

**Nominal pulse voltage:** 2,5 kV

**Category of overvoltage:** II

**Isolation:** reinforced between low voltage (input and output relay) and frontal parts. Reinforced between low voltage and very low voltage parts (input, static outputs)

### THERMOCOUPLE INPUT

**Type:** J,K,S,R,T programmable

**Line resistance:** 100 Ω with error  $\leq \pm 0.1\%$  of the input range width

**Unit of measurement:** °C or °F programmable

**Cold junction:** automatic compensation from 0 to +50 °C

**Cold junction accuracy:** 0,1 °C/°C @ 25 °C after a warm-up (instrument switch-on) of 20 min

**Calibration:** according to EN 60584-1

**Burn-out:** at the end of scale

TC Type	Range	
J	From 0 to 1000 °C	From 32 to 1832 °F
	From 0.0 to 999.9°C	From 32.0 to 999.0 °F
K	From 0 to 1370 °C	From 32 to 2498 °F
	From 0.0 to 999.9°C	From 32.0 to 999.0 °F
S	From 0 to 1760 °C	From 32 to 3200 °F
	From 0.0 to 999.9°C	From 32.0 to 999.0 °F
R	From 0 to 1760 °C	From 32 to 3200 °F
	From 0.0 to 999.9°C	From 32.0 to 999.0 °F
T	From 0 to 400 °C	From 32 to 752 °F
	From 0.0 to 400.0°C	From 32.0 to 752.0 °F

### THERMORESISTANCE INPUT (RTD)

**Type:** Pt 100 3 wires

**Current:** 135 µA

**Line resistance:** automatic compensation up to 20 Ω/wire with maximum error  $\leq \pm 0.1\%$  of the input span.

**Unit of measurement:** °C or °F programmable

**Burn-out:** at the end of scale

**Calibration:** according to EN 60751/A2

RTD Type	Range	
Pt 100	From -200 to 850 °C	From -328 to 1562 °F
	From -200.0 to 850.0 °C	From -328.0 to 999.9 °F

### THERMISTOR INPUT

**Type:** KTY 81-121 (990 Ω @ 25 °C) and

NTC 103AT-2 (10 KΩ @ 25 °C)

**Unit of measurement:** °C or F, programmable

Type	Range	
KTY 81-121	From -55 to 150 °C	From -67 to 302°F
	From -55.0 to 150.0 °C	From -67.0 to 302.0 °F
NTC103 AT-2	From -50 to 110 °C	From -58 to 230°F
	From -50.0 to 110.0 °C	From -58.0 to 230.0 °F

### LINEAR SIGNALS INPUT

**Type:** 0/10-50 mV, 0/12-60 mV, 0/4-20 mA, 0/1-5 V, 0/2-10 V

**Visualization:** programmable from -1999 to 9999

**Decimal point:** programmable

**Burn-out:** (only for zero suppression signals) Burn-out signaling when the input signal is less than 5% of the input field

**Auxiliary supply for 0/4 - 20 mA transmitters:**

- **Type:** not isolated and not protected against short-circuit

- **Load:** 10 V @ 20 mA.

**Input impedance:**

- 51 Ω for mA input

- >1 MΩ for mV and V inputs

### DIGITAL INPUTS

**Type:** for free-voltage contacts

**Max contact resistance:** 10 Ω

**Contact load:** 10 V, 6 mA

### OUTPUTS

**Function:** programmable

**Output action:** direct/reverse, programmable

**Type:**

a) Relay outputs

**Contact:** - SPDT or SPST-NO

**Contact Load:** see the "How to order"

**Relay electric life:** 100000 operations

b) Logic tension to drive a solid state relay

**Isolation:** Output NOT isolated as regards the very low voltage parts

**Logic state 1:** 12 V  $\pm 20\%$  @ 1 mA

10 V  $\pm 20\%$  @ 20 mA

**Logic state 0:** <0.5 V

### POWER OUTPUT SENSOR

**Isolation:** Output not isolated and not protected by the short circuit

**Tension:** 12 VDC

**Current:** 20 mA Max

### COMMUNICATION

**Type:** TTL Modbus and RS 485 (optional)

**Isolation:** functional isolation (50 V) with respect to the very low voltage parts

**Protocol:** Modbus RTU

**Electrical levels:** according to EIA standards

**Baud rate:** from 1200 to 38000 baud

**Parity:** none

**Data formed:** 8 bit + 1 start bit + 1 stop bit

### ENVIRONMENTAL DATA

**Pollution category:** 2

**Installation category:** II

**Operating temperature:** from 0 to 50 °C

**Operating humidity:** < 95 RH% without condensation

**Storage temperature:** -25 °C to 60 °C

### FUNCTIONAL DATA

**Control:** - single action PID, double action PID

- ON/OFF, Neutral Zone ON/OFF

**Overall accuracy:**  $\pm (0,5\% \text{ span} \pm 1 \text{ digit @ } 25\text{ °C})$ ;

Tc S:  $\pm (1\% \text{ span} \pm 1 \text{ digit @ } 25\text{ °C})$

**Sampling rate:** 130 ms

**Display updating time:** 500 ms

**Common-mode rejection:** 120 dB to 50/60 Hz

**Normal-mode rejection:** 60 dB to 50/60 Hz

**Conformity:** EMC 2004/108/CE (EN 61326) Directive, LV 2006/95/CE (EN 61010-1) Directive.

# K 85

4 DIN module - up to 3 outputs



# K 85

### MECHANICAL DATA

- Housing:** UL 94 V0 self-extinguishing plastic
- Mounting:** on Omega DIN rail
- Dimensions:** 4 DIN module, 70 x 84 mm, depth 60 mm
- Display:** 4 Red Digit h 12 mm
- Weight:** 180 g approx.
- Terminal block:** 24 screw terminals (screw M3 for cables from 0.25 to 2.5 mm<sup>2</sup> or from AWG 22 to AWG 14)
- Protection degree:** IP 40 (screw terminal IP20) according to EN 60070-1 for indoor use.

### DIMENSIONS (mm)

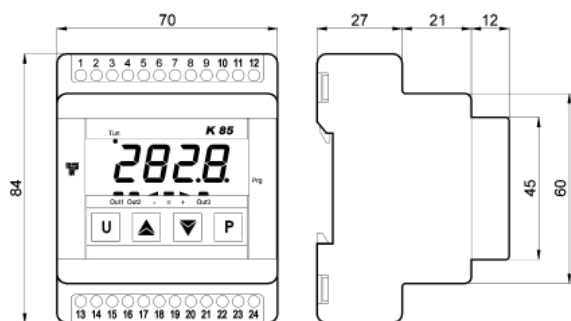

### HOW TO ORDER

- K85** - Controller
- K85T** = Controller + timer
- K85P** = Controller + timer + programmer

#### Power supply

- L** = 24 V AC/DC
- H** = 100 - 240 V AC/DC

#### Input

- C** = J, K, R, S, T, PT100, 0/12...60 mV
- E** = J, K, R, S, T, PTC, NTC, 0/12...60mV
- I** = 0/4...20 mA
- V** = 0...1V, 0/1...5V, 0/2...10V

#### Out 1

- R** = SPDT 8 A Relay (resistive)
- O** = VDC for SSR

#### Out 2

- = Not available
- R** = SPST 8 A Relay (resistive)
- O** = VDC for SSR

#### Out 3

- = Not available
- R** = SPST-NO 5 A Relay (resistive)
- O** = VDC for SSR

#### Communication

- = TTL ModBus
- S** = RS 485 ModBus

#### Digital input

- = Not available
- D** = 2 digital inputs

### CONNECTIONS

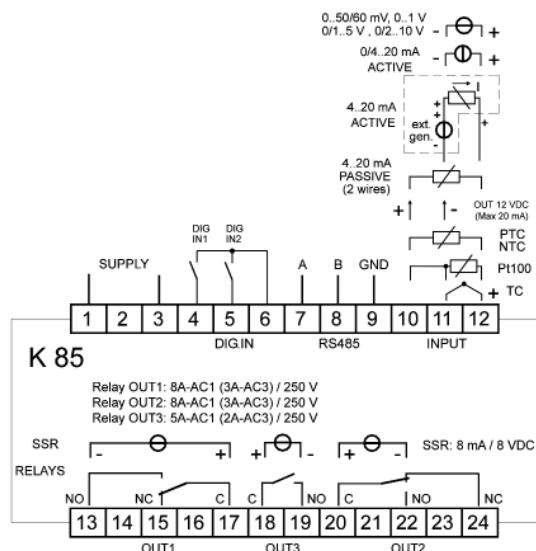

#### HOW TO ORDER

- K31/ K32 (\*) - = Controller
- K31/ K32 (\*) T = Controller + timer
- K31/ K32 (\*) P = Controller + timer + programmer

(\*) K32: Add the code **S** to have "Sensitive Touch" keyboard .

#### Power supply

- F = 12 V AC/DC
- L = 24 V AC/DC (available soon)
- H = 100 - 240 V AC/DC

#### Input

- C = J, K, R, S, T, PT100, 0/12...60 mV + 2 Digital Inputs
- E = J, K, R, S, T, PTC, NTC, 0/12...60mV + 2 Digital Inputs
- I = 0/4...20 mA + 2 Digital Inputs
- V = 0...1V, 0/1...5V, 0/2...10V + 2 Digital Inputs

#### Out 1

- R = SPDT 8 A relay (resistive)
- O = VDC for SSR

#### Out 2

- = Not available
- R = SPDT 8 A Relay (resistive)
- O = VDC for SSR

#### Out 3

- = Not available
- R = SPST-NO 5 A Relay (resistive)
- O = VDC for SSR

#### Out 4

- = Not available
- R = SPST-NO 5 A Relay (resistive)
- O = VDC for SSR

#### Communication

- = TTL ModBus
- S = RS 485 ModBus



### K 31

#### Single display



### K 32

#### Double display



#### MECHANICAL DATA

**Housing:** UL 94 V0 self-extinguishing plastic

**Keyboard:** mechanical or "Sensitive Touch" type

**Mounting:** flush in panel

**Dimensions:** 78 x 35 mm, depth 75,5 mm

**Panel cut-out:** 71 (-0 to +0,6 mm) x 29 (-0 to +0,5 mm)

**Display:** K31 - 4 Digit single display, red colour, h 12 mm + 3 LED Bargraph  
K32 - 4 Digit double display, red and green colour, h 7 mm.

**Weight:** 180 g approx.

**Screw terminals:** 24 screw terminals (screw M3 for cables from 0.25 to 2.5 mm<sup>2</sup> or from AWG 22 to AWG 14)

**Protection Degree:**

- Front protection: IP 65 (with gasket) according to EN 60070-1 for indoor use
- Screw terminal: IP20.

#### DIMENSIONS (mm)

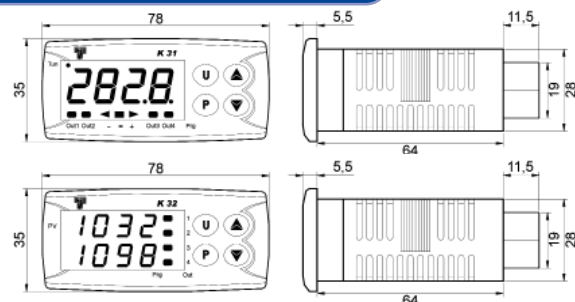

#### CONNECTIONS

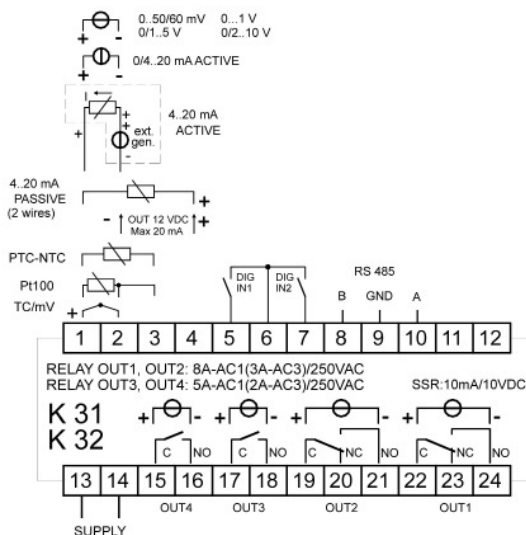

# K 38-39

78 x 35 - up to 2 outputs



## K 38 Single display



## K 39 Double display

### MECHANICAL DATA

**Housing:** UL 94 V0 self-extinguishing plastic

**Mounting:** flush in panel

**Dimensions:** 75 x 33 mm, depth 64 mm

**Panel cut-out:** 71 (-0 to + 0,6 mm) x 29 (-0 to +0,5 mm)

**Display:** **K38** - 4 Digit single display, red colour, h 12 mm + 3 LED Bargraph  
**K39** - 4 Digit double display, red and green colour, h 7 mm

**Weight:** 180 g approx.

**Screw terminals:** 12 screw terminals (screw M3 for cables from 0.25 to 2.5 mm<sup>2</sup> or from AWG 22 to AWG 14)

**Protection Degree:**

- Front protection: IP 65 (with gasket) according to EN 60070-1 for indoor use
- Screw terminal: IP20.

### CONNECTIONS

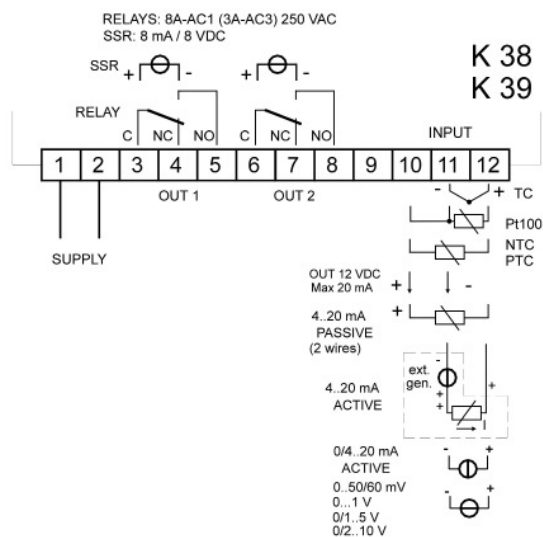

### HOW TO ORDER

- K38** - Controller single display
- K38T** = Controller + timer
- K38P** = Controller + timer + programmer
- K39** - Controller double display
- K39T** = Controller + timer
- K39P** = Controller + timer + programmer

#### Power supply

- F** = 12 V AC/DC
- L** = 24 V AC/DC
- H** = 100 - 240 V AC/DC

#### Input

- C** = J, K, R, S, T, PT100, 0/12...60 mV
- E** = J, K, R, S, T, PTC, NTC, 0/12...60mV
- I** = 0/4...20 mA
- V** = 0...1V, 0/1...5V, 0/2...10V

#### Out 1

- R** = SPDT 8 A Relay (resistive)
- O** = VDC for SSR

#### Out 2

- = Not available
- R** = SPDT 8 A Relay (resistive)
- O** = VDC for SSR

### DIMENSIONS (mm)

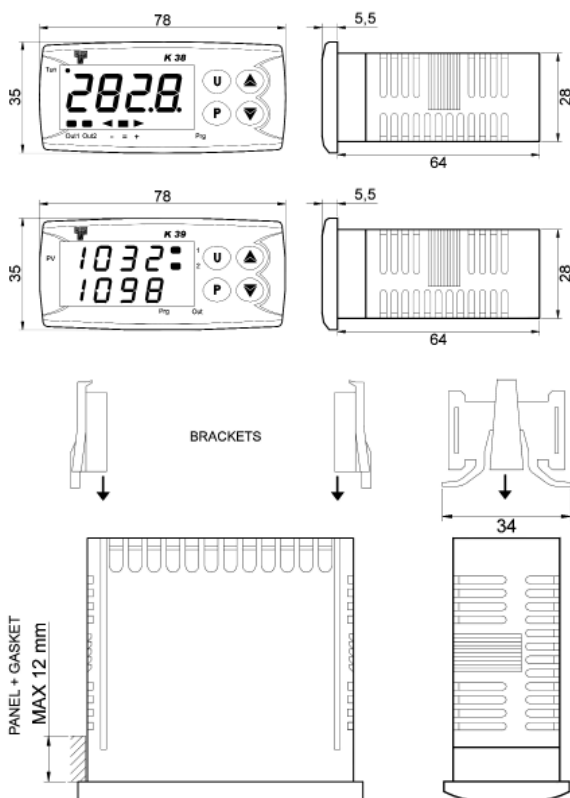

#### HOW TO ORDER

- K48 - Controller single display
- K48T = Controller + timer
- K48P = Controller + timer + programmer
- K49 - Controller double display
- K49T = Controller + timer
- K49P = Controller + timer + programmer

#### Power supply

- L = 24 V AC/DC
- H = 100 - 240 V AC/DC

#### Input

- C = J, K, R, S, T, PT100, 0/12...60 mV
- E = J, K, R, S, T, PTC, NTC, 0/12...60mV
- I = 0/4...20 mA
- V = 0...1V, 0/1...5V, 0/2...10V

#### Out 1

- R = SPST-NO 8 A Relay (resistive)
- O = VDC for SSR

#### Out 2

- = Not available
- R = SPST-NO 8 A Relay (resistive)
- O = VDC for SSR

#### Out 3 / Digital inputs

- = Not available
- R = SPST 5 A Relay (resistive)
- O = VDC for SSR
- D = 2 digital inputs



**K 48**  
Single display

**K 49**  
Double display

#### MECHANICAL DATA

**Housing:** UL 94 V0 self-extinguishing plastic

**Mounting:** flush in panel

**Dimensions:** 48 x 48 mm (1/8 DIN), depth 98 mm

**Panel cut-out:** 45 (-0 to +0,6 mm) x 45 (-0 to +0,5 mm)

**Display:** K48 - 4 Digit single display, red colour, h 12 mm + 3 LED Bargraph  
K49 - 4 Digit double display, red and green colour, h 7 mm.

**Weight:** 180 g approx.

**Screw terminals:** 12 screw terminals (screw M3 for cables from 0.25 to 2.5 mm<sup>2</sup> or from AWG 22 to AWG 14)

**Protection Degree:**

- Front protection: IP 54 (with gasket) according to EN 60070-1 for indoor use
- Screw terminal: IP20.

#### DIMENSIONS (mm)

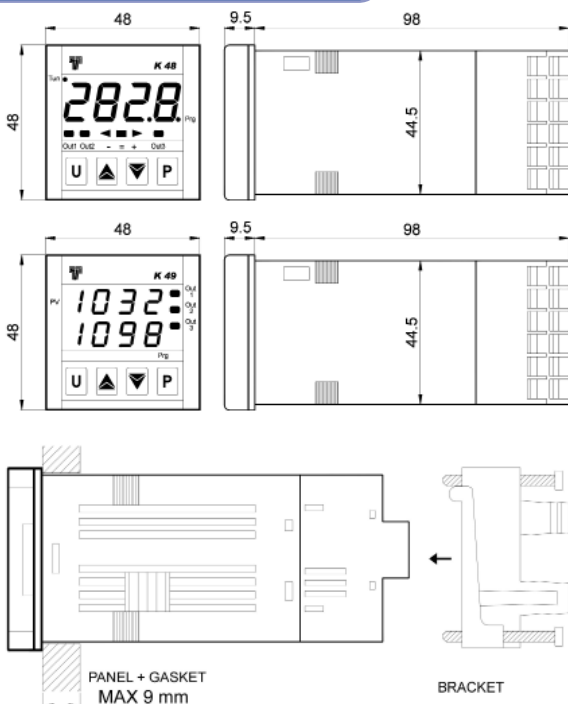

#### CONNECTIONS

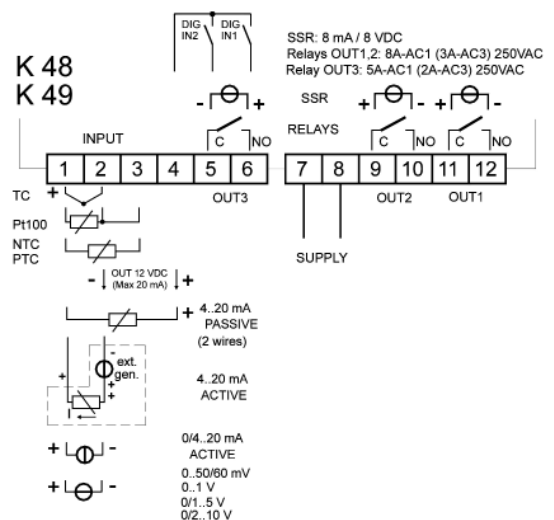

CANADA  
USA  
MEXICO  
VENEZUELA  
BRAZIL

IRELAND  
UK  
PORTUGAL  
SPAIN  
FRANCE  
BELGIUM  
HOLLAND  
LUXEMBOURG  
DENMARK  
GERMANY  
SWITZERLAND  
AUSTRIA  
FINLAND  
NORWAY  
SWEDEN



SLOVENIA  
POLAND  
HUNGARY  
CZECH REP.  
ROMANIA  
GREECE  
ALGERIA  
TUNISIA  
MOROCCO  
EGYPT  
JORDAN  
ISRAEL  
SYRIA  
SOUTH AFRICA

CSI  
LATVIJA  
KAZAKHSTAN  
TURKEY  
SINGAPORE  
HONG KONG  
THAILAND  
TAIWAN  
CHINA  
AUSTRALIA  
NEW ZEALAND

## TECNOLOGIC IN THE USA

**CONTROLTEC INCORPORATED**  
8, FOUR COINS DRIVE  
CANONSBURG, PA 15317- U.S.A.  
TEL. 001/7247461901  
FAX 001/7247462021  
e-mail: [info@controlteconline.com](mailto:info@controlteconline.com)  
<http://www.controlteconline.com>



This publication belongs exclusively to Tecnologic S.p.A. and may not be reproduced unless with expressed authorisation. Tecnologic S.p.A. reserves the right to make modifications without warning.

COMPANY WITH QUALITY MANAGEMENT  
SYSTEM CERTIFIED BY DNV  
= ISO 9001:2000 =