

# TLZ 20

## MICROPROCESSOR-BASED DIGITAL ELECTRONIC FREEZER CONTROLLER



### OPERATING INSTRUCTIONS



8 Four Coins Drive  
Canonsburg, PA 15317  
1-800-566-3883  
724-746-1901  
[www.controlteconline.com](http://www.controlteconline.com)



#### FOREWORD

This manual contains the information necessary for the product to be installed correctly and also instructions for its maintenance and use; we therefore recommend that the utmost attention is paid to the following instructions.

Though this manual has been issued with the greatest care, CONTROLTEC will not take any responsibility deriving from its use. The same applies to each person or Company involved in the issuing of this manual.

This document is the exclusive property of CONTROLTEC which forbids any reproduction and divulgation, even in part, of the document, unless expressly authorized.

CONTROLTEC reserves the right to make any formal or functional changes without notice.

#### INDEX

- 1 **INSTRUMENT DESCRIPTION**
  - 1.1 GENERAL DESCRIPTION
  - 1.2 FRONT PANEL DESCRIPTION
- 2 **PROGRAMMING**
  - 2.1 PROGRAMMING OF SET POINT
  - 2.2 PARAMETERS PROGRAMMING
  - 2.3 PARAMETER PROTECTION USING THE PASSWORD
  - 2.4 PARAMETERS PROGRAMMING LEVEL
  - 2.5 ON / STAND-BY FUNCTION
- 3 **INFORMATION ON INSTALLATION AND USE**
  - 3.1 PERMITTED USE
  - 3.2 MECHANICAL MOUNTING
  - 3.3 ELECTRICAL CONNECTIONS
  - 3.4 ELECTRICAL WIRING DIAGRAM
- 4 **FUNCTIONS**
  - 4.1 MEASURING AND VISUALIZATION
  - 4.2 TEMPERATURE CONTROL
  - 4.3 COMPRESSOR PROTECTION FUNCTION AND DELAY AT POWER-ON
  - 4.4 DEFROST CONTROL
  - 4.5 MANUAL DEFROST
  - 4.6 FUNCTION OF KEY "U"
  - 4.7 PARAMETERS CONFIGURATION BY KEY01
- 5 **PROGRAMMABLE PARAMETERS TABLE**
- 6 **PROBLEMS , MAINTENANCE AND GUARANTEE**
  - 6.1 SIGNALING
  - 6.2 CLEANING
  - 6.3 GUARANTEE AND REPAIRS
- 7 **TECHNICAL DATA**
  - 7.1 ELECTRICAL DATA
  - 7.2 MECHANICAL DATA
  - 7.3 MECHANICAL DIMENSIONS, PANEL CUT-OUT AND MOUNTING
  - 7.4 FUNCTIONAL DATA
  - 7.5 INSTRUMENT ORDERING CODE

#### 1 - INSTRUMENT DESCRIPTION

##### 1.1 - GENERAL DESCRIPTION

The model TLZ 20 is a digital microprocessor based controller that is typically used in cooling applications that have temperature control with ON/OFF regulation and defrosting control with set time by means of the stopping compressor.

The instrument has one relay output and one input for PTC or NTC temperature probes.

The instrument is equipped with 4 program keys, a 4-digit display and 2 LED signals.

Other important characteristics of the instrument are: program protection using personalized password, turning the instrument on and off (stand-by) using the "U" key, configuration of parameters via the KEY 01 device and more.

##### 1.2 - FRONT PANEL DESCRIPTION

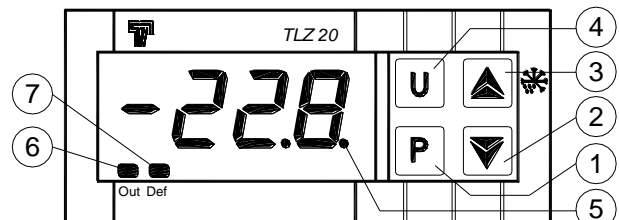

**1 - Key P** : Used for setting the Set point and for programming the function parameters

**2 - Key DOWN** : Used for decreasing the values to be set and for selecting the parameters.

**3 - Key UP/DEFROST** : Used for increasing the value to be set, for selecting the parameters and for activating manual defrost.

**4 - Key U** : It can be programmed via the parameter "USrb" to turn the device on and off (stand-by). In the "hidden" parameter

programming mode it's used to modify the visibility of the parameters (see par. 2.4).

**5 - Led SET** : Lights when in programming mode and indicates the programming level of the parameters. It also serves to indicate the Stand-by status.

**6 - Led OUT** : Indicates the compressor output status (or the temperature control device) on (on), off (off) or inhibited (flashing).

**7 - Led DEF** : Indicates defrosting in progress (on) or dripping (flashing).

## 2 - PROGRAMMING

### 2.1 - PROGRAMMING OF THE SET POINT

Press the key **P** then release it and the display will show **SP** alternating with the set value.

To change, press the UP key to increase the value or DOWN to decrease it.

These keys increase or decrease the value one digit at a time, but if the button is pressed for more than one second the value increases or decreases faster, and after two seconds, the speed increases to its fastest level to reach desired values rapidly.

Exiting the Set mode is achieved by pressing the P key or if no key is pressed for 15 seconds the display automatically returns to the normal function mode.

### 2.2 - PARAMETERS PROGRAMMING

To access the instrument's function parameters, press the **P** key and keep it pressed for about 5 seconds, after which the SET led will light, the display will show the code that identifies the first parameter.

Using the UP and DOWN keys, the desired parameter can be selected and by pressing the P key again, the display will alternately show the parameter code and its setting that can be changed with the UP and DOWN keys.

Once the desired value has been set, press the P key: the new value will be memorized and the display will show only the code of the selected parameter.

By pressing the UP and DOWN keys, it is possible to select another parameter and change it as described above.

To exit the programming mode, do not press any key for about 15 seconds, or keep the UP or DOWN key pressed until it exits the programming mode.

### 2.3 - PARAMETER PROTECTION USING THE PASSWORD

The instrument has a parameter protection function using a password that can be personalized, through the "**PASS**" parameter.

If one chooses to have this protection, set the password number desired in the parameter "PASS".

When the protection is turned on, press the P key to access the parameters and keep it press for about 5 seconds, after which the LED SET will flash and the display will show "0".

At this point, using the UP and DOWN keys, scroll to the password number programmed and press the key "P".

If the password is correct, the display will show the code that identifies the first parameter and it will be possible to program the instrument in the same manner described above.

Protection using a password can be disabled by setting the parameter "PASS" = OFF.

### 2.4 - PARAMETERS PROGRAMMING LEVELS

The instrument has two parameter programming levels.

The first level ("visible" parameters) is accessed according to the procedure described above (with or without password request) while the second level ("hidden" password) can be accessed according to the following procedure.

Remove power supply to the instrument, press the key P and reapply power to the instrument, keeping the key pressed.

After about 5 seconds. the SET led will light up, the display will show the code that identifies the first parameter and it will be possible to set the parameters of the instrument using the same programming procedure described previously.

Once the parameter has been selected and the SET Led is on, it means that the parameter can be programmed on the first level ("visible").

If the LED is off it means that the parameter can only be programmed on this level (i.e. "hidden").

To change the visibility of the parameter, press the U key: the led SET will change status, indicating the accessibility level of the parameter (on = parameter "visible"; off = parameter "hidden").

The access procedure for "hidden" parameters allows the "PASS" parameter to be checked and changed, and is therefore useful if the password setting has been forgotten.

### 2.5 - ON / STAND-BY FUNCTION

The instrument, once powered up, can assume 2 different conditions:

- ON : means that the controller uses the control functions.

- STAND-BY : means that the controller does not control the process and the display is turned off except for the green SET led.

If there is a loss of power, when power returns, the system always returns to the condition it was in before power loss.

The ON/Stand-by function can be selected using the key U if the parameter "USrb" = 1 (see par. 4.8)

## 3 - INFORMATION ON INSTALLATION AND USE



### 3.1 - PERMITTED USE

The instrument has been projected and manufactured as a measuring and control device to be used according to EN61010-1 for the altitudes operation to 2000 ms.

The use of the instrument for applications not expressly permitted by the above mentioned rule must adopt all the necessary protective measures.

The instrument CANNOT be used in dangerous environments (flammable or explosive) without adequate protection.

The installer must ensure that EMC rules are respected, also after the instrument installation, if necessary using proper filters.

Whenever a failure or a malfunction of the device may cause dangerous situations for persons, things or animals, please remember that the process has to be equipped with additional devices which will guarantee safety.

### 3.2 - MECHANICAL MOUNTING

The instrument, in the 33 x 75 mm enclosure, is designed for mounting flush to the panel.

Cut a hole 29 x 71 mm and insert the instrument, securing it with the special bracket provided.

We recommend that a gasket be used to obtain the IP 65 front protection rating.

Avoid placing the instrument in environments with very high humidity levels or dirt that may create condensation or introduction of conductive substances into the instrument.

Ensure adequate ventilation to the instrument and avoid installation in enclosures that house devices which may overheat or may cause the instrument to function at a temperature higher than our specifications allow.

Connect the instrument as far away as possible from sources of electromagnetic disturbances such as motors, power relays, relays, solenoid valves, etc.

### 3.3 - ELECTRICAL CONNECTION

Connect only one wire to each terminal, according to the following diagram, checking that the power supply is the same as that indicated on the instrument and that the current load through the outputs is no higher than the maximum current permitted in the specifications.

As the instrument is not equipped with either switches or internal devices to protect against overload of current: the installation must include an overload protection device and a two-phase circuit-breaker, placed as near as possible to the instrument, and located in a position that can easily be reached by the user and marked appropriately to shut off the power supply to the equipment.

It is also recommended that the supply of all the electrical circuits connected to the instrument be protected properly, using devices (ex. fuses) proportionate to the expected currents.

It is strongly recommended that cables with proper insulation be used according to the working voltages and temperatures.

Furthermore, the input cable of the process sensing probe has to be kept separate from line voltage wiring. If the input cable of the probe is screened, it has to be connected to the ground with only one side.

When the instrument is 12 V version, it's recommended to use an external transformer (model TCTR) or similar, and to use only one transformer for each instrument because there is no insulation between supply and input.

We recommend that the parameter settings be verified to make certain the desired values have been selected for the application before connecting the outputs to the process. This should be done to avoid a malfunction that could cause damage to people, things or animals.

**ControlTec, Inc and its legal representatives do not assume any responsibility for any damage to people, things or animals deriving from violation, wrong or improper use or in non compliance with the instrument's features.**

### 3.4 - ELECTRICAL WIRING DIAGRAM

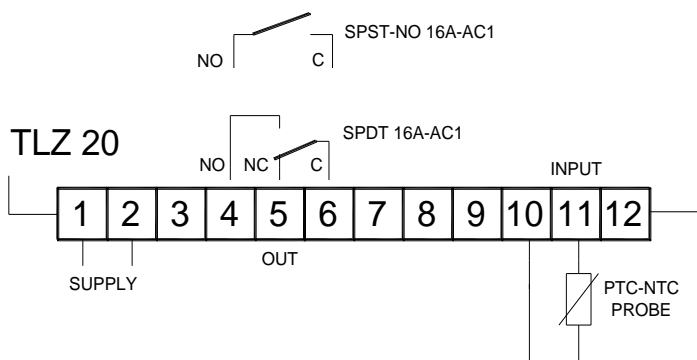

## 4 - FUNCTIONS

### 4.1 - MEASURING AND VISUALIZATION

Via the parameter "SEnS" it is possible to select the type of probes that one wishes to use. These can be: thermistors PTC KTY81-121 (Ptc) or NTC 103AT-2 (ntc).

Through the parameter "Unit", it is possible to select the temperature unit of measurement (°C or °F)

Through the parameter "dP", the resolution of the desired measurement (OFF=1°; On =0,1°).

The instrument allows the process measurement to be calibrated according to application needs, through the parameters "OFS".

Using the parameter "FiL", it is possible to change the timing of the software filter for the input values to reduce sensitivity to measurement disturbances. Providing less Led display fluctuation. Please remember that the displayed value from the probe can also be changed using the display block in defrosting function by using the parameter "dLo" (see par. 4.4).

### 4.2 - TEMPERATURE CONTROL

The control scheme of the instrument is ON/OFF and regulates the output "OUT" depending on the temperature the probe is measuring, value of the Set Point "SP", the intervention differential "HSEt" and the function mode "Func".

Depending on the function mode programmed on parameter "Func" the differential is automatically assigned by the controller with positive values for a Refrigeration control ("Func"=Cool) or with negative values for a heating control ("Func"=HEAT).

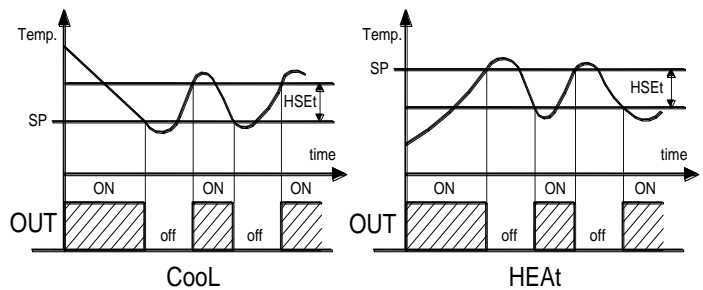

In the event of probe error, it is possible to set the instrument so the output "OUT" continues to work in cycles according to the times programmed in the parameter "tonE" (activation time) and "toFE" (deactivation time).

If an error occurs with the probe, the instrument activates the output for the time "tonE", then deactivates it for the time "toFE" and so on while the error remains.

Programming "tonE" = OFF the output in a probe error condition will remain switched off.

Programming instead "tonE" to any value and "toFE" = OFF the output in a probe error condition will remain switched on.

Remember that the temperature control function can also be managed by the "Compressor Protection" function described below.

### 4.3 - COMPRESSOR PROTECTION FUNCTION AND DELAY AT POWER-ON

The function "Compressor Protection" carried out by the controller aims to avoid "short starts" of the compressor controlled by the instrument in cooling applications.

This function allows a time buffer for switching of the "OUT" output associated with a temperature regulation request.

The protection consists of preventing the output from being switched on during the time set in the parameter "PtC" depending on how parameter "PSC" has been programmed.

Activation occurs only after the "PtC" time has elapsed.

During the power on delay phase, if the request for cooling is no longer needed for any reason the switching of the output is cancelled.

Using the parameter "PSC", it is possible to set the type of compressor protection required and therefore when the inhibition time "PtC" must start.

The parameter "PSC" can be set as:

= 1: Power on delay

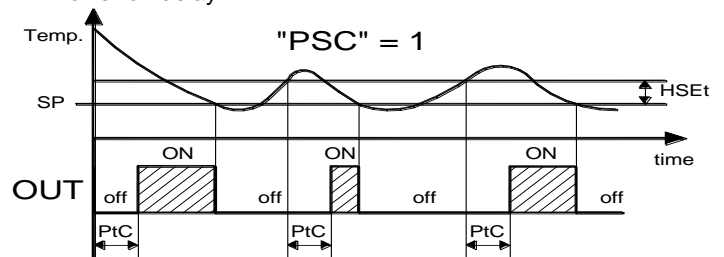

= 2: Delay after power off

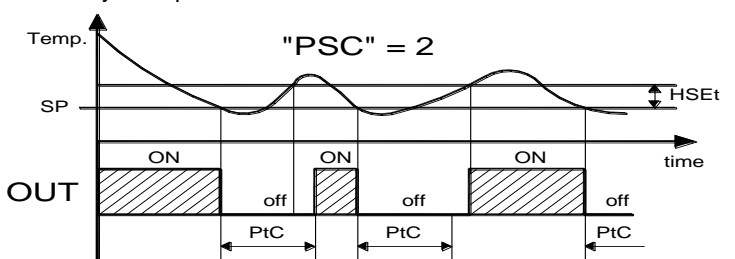

= 3 : Delay between power on phases.

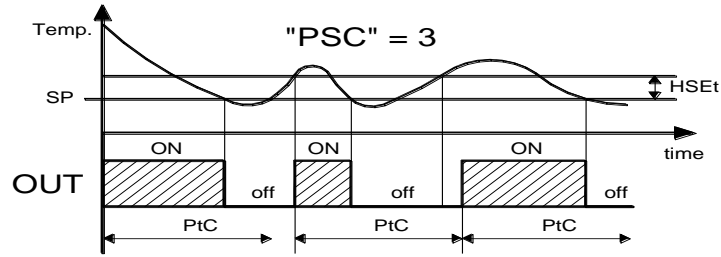

This function is disabled by programming "PtC" = 0.  
 During the power on delay phases the led OUT flashes.  
 It is also possible to prevent switching of the output after the instrument is first turned on for the time set in the parameter "od".  
 The function is disabled by "od" = OFF.  
 During the power on delay phase, the display indicates **od**, alternating with the normal display of temperature.

#### 4.4 - DEFROST CONTROL

The automatic control of defrost via stopping the compressor occurs according to these parameters:

- "dCt" : Defrost interval computation
  - rt - based on real time (instrument on time)
  - ct - based only on compressor run times (output on)
- "dint" : Interval between defrost cycles
- "dEFE" : Length of defrost cycles

The instrument switches the output off for the time "dEFE" each "dint" time (or real time functioning if "dCt" = rt, or by compressor running time if "dCt" = ct).

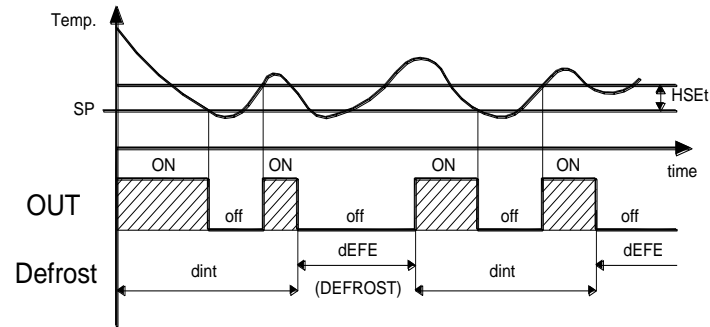

(ex. with "dC" = rt)

An active defrost cycle is shown by the led DEF.  
 Through par. "dLo", "Etdu" and "dALd" it's possible to choose what to display during defrost.

The "dLo" parameter locks the display on the last temperature reading (dLo = On) before starting a defrost cycle until the end of defrost. The temperature must reach the value [SP + Etdu] or the time set on par. "dALd" before process temperature will be displayed.

Or you can choose to display "dEF" ("dLo" = Lb) during the defrost cycle. After the defrost, the display shows "PdEF" until the end of defrost but the temperature must reach the value [SP + Etdu] or the time set on par. "dALd" must elapse before the actual temperature will be displayed.

The display will continue to show the temperature measured by the probe during the defrost cycle if parameter "dLo" = OFF.

#### 4.5 - MANUAL DEFROST

To start a manual defrost cycle, press the UP/DEFROST key when not in programming mode and keep it pressed for about 5 seconds after which, if the conditions are correct, the DEF led will light up and the instrument will begin a defrosting cycle.

#### 4.6 - FUNCTIONING OF "U" KEY

The U key function can be defined by the parameter "USrb" and can be configured for the following functions:

= OFF - The key U has no function.

= 1 - Pressing the key for at least 1 second, it is possible to switch the instrument from the ON condition to Stand-by condition and vice versa.

#### 4.7 - PARAMETERS CONFIGURATION BY "KEY01"

The instrument is equipped with a connector that allows functioning parameters to be transferred to and from the instrument using the KEY01 device with 5 pole connector.

This device it's used for rapid programming of multiple instruments that need to have the same configuration parameters.

To use the device KEY01 it's necessary that either the device or instrument is supplied with a power source.

#### Instrument powered and device not powered

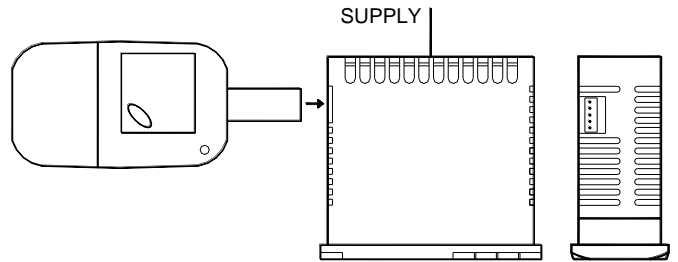

#### Instrument powered from the device

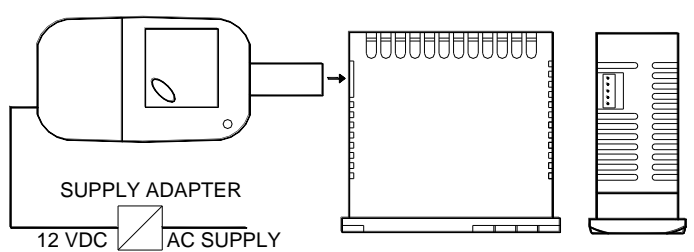

To transfer the configuration of an instrument into the device (**UPLOAD**) it is necessary to do the following:

- 1) Position both dip switches of KEY 01 in the **OFF** mode.
- 2) Connect the device to the TLZ's serial connection port.
- 3) Verify that the instrument or the device have power.
- 4) Observe the indication led on the KEY 01 device: if it is green this means that a configuration is already loaded on the device. If it is blinking green or red this means that no configuration has been loaded.
- 5) Press the button on the device.
- 6) Observe the indication led : after pressing the button, the led will turn red. At the end of the data transfer, it will change to green.
- 7) It is now possible to disconnect the device.

To transfer the configuration loaded on the device into an instrument of the same family (**DOWNLOAD**), it is necessary to do the following:

- 1) Position both dip switches of KEY 01 in the **ON** mode.
- 2) Connect the device to a TLZ having the same features as the one used to originally program the KEY01.
- 3) Verify that the instrument or the device have power.
- 4) Observe the indication led on the device: it must show a steady green light. If the led blinks green or red, there are no valid configurations loaded on the device.
- 5) If the led shows a steady green, press the button on the device.
- 6) Observe the indication led : after pressing the button, the led will turn red. At the end of the data transfer, it will change to green.

## 5 - PROGRAMMABLE PARAMETERS TABLE

Below is a description of all the parameters available on the instrument. Some of them may not be present, depending on the type of instrument or because they are automatically disabled and unnecessary based on other settings previously made.

Par.	Description	Range	Def.	Note
1	<b>SPLL</b>	Minimum Set Point	-58.0 ÷ SPHL	-50.0
2	<b>SPHL</b>	Maximum Set Point	SPLL ÷ 302.0	100.0
3	<b>SEnS</b>	Probe Type	Ptc - ntc	Ptc
4	<b>OFS</b>	Probe Calibration	-30.0 ÷ 30.0 °C/°F	0.0
5	<b>Unit</b>	Unit of measurement	°C - °F	°C
6	<b>dP</b>	Decimal point	On - OFF	On
7	<b>FIL</b>	Measurement filter	OFF ÷ 20.0 sec	2.0
8	<b>HSEt</b>	Differential	0.0 ÷ 30.0 °C/°F	2.0
9	<b>tonE</b>	Activation time output OUT for probe broken	OFF ÷ 99.59 min.sec	OFF
10	<b>toFE</b>	Deactivation time output OUT for probe broken	OFF ÷ 99.59 min.sec	OFF
11	<b>Func</b>	Function mode output OUT	HEAt - Cool	Cool
12	<b>dint</b>	Defrosting interval	OFF ÷ 24.00 hrs.min	6.00
13	<b>dEFE</b>	Length of defrost cycle	0.01 ÷ 99.59 min.sec	30.00
14	<b>dCt</b>	Defrosting intervals Counting mode: rt = real time ct = On OUT time	rt - ct	rt
15	<b>dLo</b>	Defrost display Lock: OFF= display free On= Lock on temperature before defrost Lb= Lock on label "dEF" (during defrosting) and "PdEF" (during post-defrosting)	On - OFF - Lb	OFF
16	<b>Etdu</b>	Differential display unlock after defrost	0.0 ÷ 30.0 °C/°F	2.0
17	<b>PSC</b>	Type of compressor protection: 1= delay at switch on 2= delay after switch off 3= delay between starts	1 - 2 - 3	1
18	<b>PtC</b>	Compressor protection time	OFF ÷ 99.59 min.sec	OFF
19	<b>od</b>	Delay at power on	OFF ÷ 99.59 min.sec	OFF
20	<b>dALd</b>	Unlock display delay after defrost	OFF ÷ 24.00 hrs.min	1.00
21	<b>USrb</b>	Function mode key U: OFF= No Function 1= ON/STAND-BY	OFF / 1	OFF
22	<b>PASS</b>	Access Password to parameter functions	OFF ÷ 9999	OFF
23	<b>SP</b>	Set Point	SPLL ÷ SPHL	0.0

## 6 - PROBLEMS, MAINTENANCE AND GUARANTEE

### 6.1 - SIGNALLING

#### Error Signalling:

Error	Reason	Action
<b>E1</b> <b>-E1</b>	The probe may be interrupted or in short circuit, or may measure a value outside the range allowed	Check the correct connection of the probe with the instrument and check the probe works correctly
<b>EEPr</b>	Internal memory error	Check and if necessary re-programme the parameters function.

In probe error status, the output OUT behaves as set by the parameters "tonE" and "toFE".

#### Other Signalling:

Message	Reason
<b>od</b>	Delay in switching on in progress
<b>dEF</b>	Defrosting in progress with "dLo"=Lb
<b>PdEF</b>	Post-defrosting in progress with "dLo"=Lb

### 6.2 - CLEANING

We recommend cleaning the instrument with a slightly wet cloth using water. Do not use abrasive cleaners or solvents which may damage the instrument.

### 6.3 - GUARANTEE AND REPAIRS

The instrument is under warranty against manufacturing flaws or faulty material within 12 months from delivery date.

The guarantee is limited to repairs or to the replacement of the instrument.

The eventual opening of the housing, the violation of the instrument or the improper use and installation of the product will bring about the immediate withdrawal of the warranty's effects.

In the event of a faulty instrument, either within the period of warranty, or further to its expiry, please contact our sales department to obtain authorization for sending the instrument to our company.

The faulty product must be shipped to CONTROLTEC with a detailed description of the faults found, without any fees or charge for ControlTec, except in the event of alternative agreements

## 7 - TECHNICAL DATA

### 7.1 - ELECTRICAL DATA

**Power supply:** 12 VAC/VDC, 24 VAC/VDC, 100..240 VAC +/- 10%

**Frequency AC:** 50/60 Hz

**Power consumption:** 3 VA approx.

**Input/s:** 1 input for temperature probes: PTC (KTY 81-121, 990  $\Omega$  @ 25 °C) or NTC (103AT-2, 10K $\Omega$  @ 25 °C); 1 digital input for free voltage contacts

**Output/s:** 1 relay output: SPST-NO (16A-AC1, 6A-AC3 250 VAC) or SPDT 16A-AC1, 6A-AC3 250 VAC)

**Electrical life for relay outputs:** SPST-NO: 100000 op. ; SPDT: 50000 op. (om. VDE)

**Installation category:** II

**Measurement category:** I

**Protection class against electric shock:** Class II for Front panel

**Insulation:** Reinforced insulation between the low voltage part (supply H type and relay output) and front panel; Reinforced insulation between the low voltage section (supply type H and relay output) and the extra low voltage section (inputs); Reinforced between supply and relay output; No insulation between supply F type and inputs.

### 7.2 - MECHANICAL DATA

**Housing:** Self-extinguishing plastic, UL 94 V0

**Dimensions:** 33 x 75 mm, depth 64 mm

**Weight:** 115 g approx.

**Mounting:** Flush in panel in 29 x 71 mm hole

**Connections:** 2,5 mm<sup>2</sup> screw terminals block

**Degree of front panel protection :** IP 65 mounted in panel with gasket

**Pollution situation:** 2

**Operating temperature:** 0 ... 50 °C

**Operating humidity:** 30 ... 95 RH% without condensation

**Storage temperature:** -10 ... +60 °C

### 7.3 - MECHANICAL DIMENSIONS, AND MOUNTING [mm]

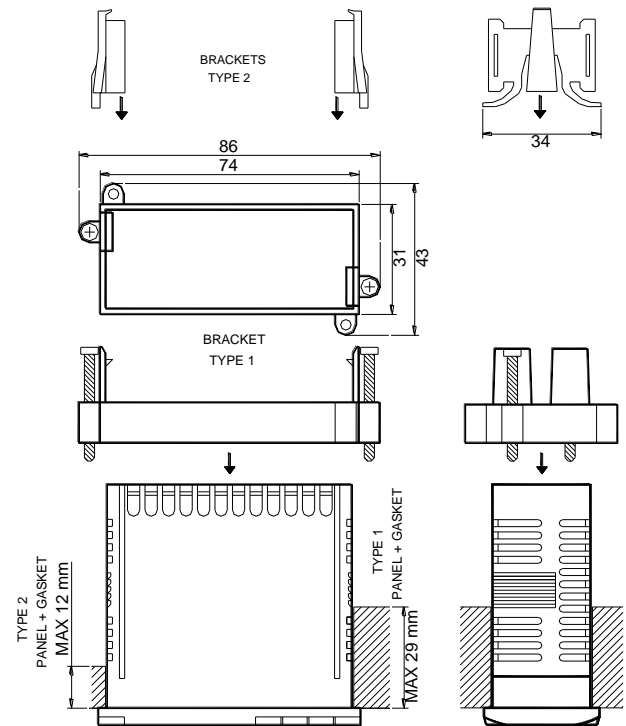
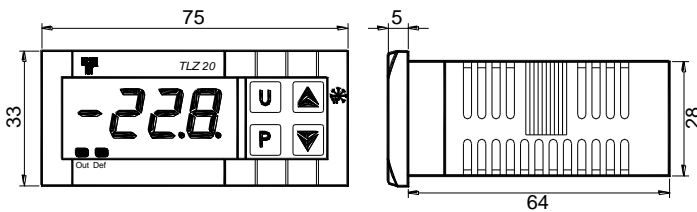

### 7.4 - FUNCTIONAL FEATURES

**Temperature Control:** ON/OFF mode

**Defrost control:** interval cycles by stopping compressor

**Measurement range:** PTC: -50...150 °C / -58 ... 302 °F;

NTC: -50...109 °C / -58...228 °F

**Display resolution:** 1 ° or 0,1°

**Overall accuracy:** +/- 0,5 % fs

**Sampling rate:** 130 ms.

**Display:** 4 Digit Red 12 mm

**Compliance:** ECC directive EMC 89/336 (EN 61326), ECC directive LV 73/23 and 93/68 (EN 61010-1)

### 7.5 - INSTRUMENT ORDERING CODE

**TLZ 20 a b**

#### **a : POWER SUPPLY**

**H** = 100...240 VAC

**L** = 24 VAC/VDC

**F** = 12 VAC/VDC

#### **b : OUTPUT OUT TYPE**

**S** = Relay SPDT 16A-AC1

**R** = Relay SPST-NO 16A-AC1