

THP 482

MICROPROCESSOR-BASED DIGITAL ELECTRONIC CONTROLLER



OPERATING INSTRUCTIONS

Vr. 03 (I - GB) - cod.: ISTR 00379

PREVIOUS STATEMENT: In this manual are contained all the necessary information for a correct installation and the instructions for the use and the maintenance of the product; we recommend, therefore, to read carefully the following instructions. The maximum care has been used in the realisation of this document, anyway TECNOLOGIC S.p.A. does not assume any responsibility deriving from the use of itself. The same consideration has to be done for each person or Company involved in the creation of this manual. The herewith issue is an exclusive property of TECNOLOGIC S.p.A. which forbids any reproduction and divulgation, although partial, if not expressly authorised. TECNOLOGIC S.p.A. reserves the right to execute aesthetically and functional modifications, at any moment and without any notice.

INDEX

- 1 GENERAL DESCRIPTION
- 1.1 FRONT PANEL
- 1.2 INSTRUMENT CODE
- 2 TECHNICAL DATA
- 3 INSTALLATION
- 4 OPERATING MODE
- 4.1 CONFIGURATION OF THE MEASURE INPUT
- 4.2 ON/OFF CONTROL
- 4.3 SIGLE ACTION PID CONTROL
- 4.4 DOUBLE ACTION PID CONTROL
- 4.5 AUTOTUNING FUNCTION
- 4.6 ANALOGUE CONTROL OUTPUTS
- 4.7 ALARM OUTPUTS OPERATING MODE
- 4.8 HEATER BREAK ALARM FUNCTION
- 5 PROGRAMMING
- 6 DESCRIPTION OF PARAMETERS
- 6.1 PARAMETERS TABLE
- 7 TROUBLES, MAINTENANCE, GUARANTEE

1 - GENERAL DESCRIPTION

THP 482 model is a "single loop" digital microprocessor based controller, with ON/OFF, PID single action, PID double action (direct and inverse) control mode and with AUTOTUNING function for PID mode. The process

value is visualised by 4 red displays (PV), the set value on 4 green displays (SP) and the outputs state is indicated by 4 leds. The instrument is foreseen to have till 2 outputs : 1 or 2 regulation outputs (C1, C2), 1 alarm output (A1) and/or Heater Break (HB) alarm ; all of them are relays, voltage output to drive solid state relays (SSR) or analogue (for C1, C2). The input accepts temperature probes (Thermocouple J,K,R,S,T and Thermoresistances PT100) or normalised analogue signals (0/1..5V, 0/2..10V, 0/4..20 mA). Furthermore the instrument is available with a current transformer input for the Heater Break function.

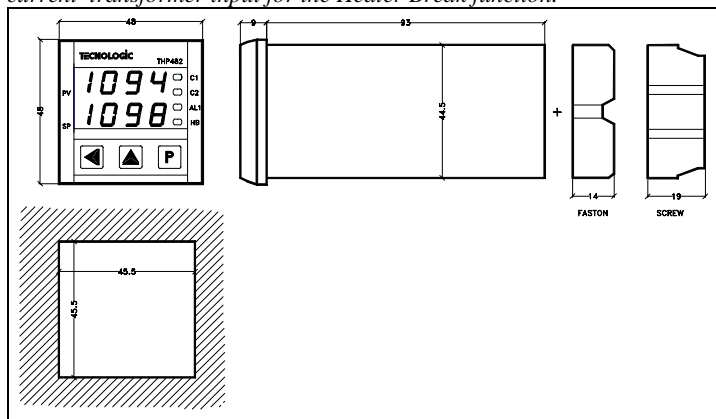

1.1 - FRONT PANEL

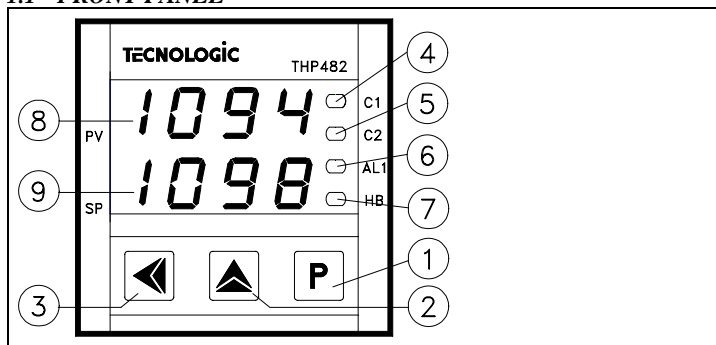

1 - **Key P** : Use to program the functioning parameters and to confirm the programmed data and pass then to the next parameter.

2 - **Key UP** : Used to increase the figure on which is placed the "cursor". In case of parameters not numerical, "UP" key is needed to select the available options

3 - **Key LEFT** : Used to shift the "cursor" (flashing) on the figure that is desired to modify, to visualise the current measured by TAHB input and to reset the alarm latch

4 - **Led C1** : Signalize when the output C1 is on (on) or off (off)

5 - **Led C2** : Signalize when the output C2 is on (on) or off (off)

6 - **Led AL1** : Signalize when the output A1 is on (on) or off (off)

7 - **Led HB** : Signalize when the output HB is on (on) or off (off)

8 - **Display PV** : Normally shows Process Value

9 - **Display SP** : Normally shows Set Point Value

1.2 - INSTRUMENT CODE

THP 482 a b cc d ee f

a = INPUT

T : For temperature probes (Thermocouples, RTD Pt100)

I : For normalized Signals 0/4...20 mA

V : For normalized Signals 0/1...5 V

W : For normalized Signals 0/2...10 V

b = PRIMARY CONTROL OUTPUT C1

R : Relay

O : 24 VDC output for SSR driving

C : Analogue 0/4...20 mA output

V : Analogue 0/2...10 V output

cc = SECONDARY OUTPUT

-- : Not present

1R : Relay alarm output (A1)

2R : Relay control output (C2)

1O : 24 VDC output for SSR driving alarm output (A1)

2O : 24 VDC output for SSR driving control output (C2)

2C : Analogue 0/4...20 mA control output (C2)
 2V : Analogue 0/2...10 V control output (C2)
 HR : Relay alarm (A1) and Heater Break alarm (HB) output
 HO : 24 VDC output for SSR driving alarm (A1) and Heater Break alarm (HB) output

d = SUPPLY

L : 24 VAC/VDC

H : 90 ... 240 VAC

ee = SPECIAL CODES

f = CONNECTIONS

F : Faston

V : Screw terminal block

2 - TECHNICAL DATA

ELECTRICAL DATA

Supply: 24 VAC/VDC, 90 ... 240 VAC +/- 10%

Frequency AC: 50/60 Hz

Power consumption: 5 VA approx.

Input/s: 1 input for temperature probes (tc J, K, R, S, T; RTD Pt 100 IEC) or or normalized signals 0/4...20 mA, 0/1...5 V, 0/2...10 V; 1 input for current transformer with K = 1/0,002 (Max. 200 mA)

Output/s: Up to 2 outputs. Relay (5 A-AC1, 2 A-AC3 / 250 VAC) ; or voltage for SSR drive (24VDC/0mA, 14VDC/20mA) or (for C1, C2) analogue with normalized 0/4...20 mA (R load < 600 Ω), 0/2...10 V (R load > 100KΩ)

Auxiliary supply output: 18 VDC / 25 mA Max (only for norm. sign..)

Electrical life for relay output : 100000 operat.

Protection class against electric shock: Class II for Front panel

Insulation: Reinforced insulation between the low voltage section (supply and relay outputs) and the front panel; Basic insulation between the low voltage section (supply and relay outputs) and the extra low voltage section (inputs and outputs for SSR or analogue); No insulation between inputs and outputs for SSR or analogue.

MECHANICAL DATA

Housing: Self-extinguishing plastic, UL 94 V0

Dimensions: 48 x 48 mm DIN, depht 107 mm (conn. faston), 112 mm (conn. screw)

Weight: 170 g approx.

Mounting: Flush in panel in 45,5 x 45,5 mm hole

Connections: 6.3 mm Faston terminals or screw terminal block 2,5 mm²

Degree of protection of front panel : IP 54 mounted in panel with gasket

Pollution situation: Normal

Operating temperature: 0 ... 55 °C

Operating humidity: 30 ... 95 RH% without condensation

Storage temperature: -10 ... +60 °C

FUNCTIONAL DATA

Control: ON/OFF, PID

Measurement range: according to the used probe (see table range)

Display resolution: according to the probe used 1/0,1

Overall accuracy: +/- 0,25 %fs

Sampling rate: 1 sample per second

Action: 1C type according to EN 60730-1

Compliance: ECC directive EMC 89/336 (EN 50081-1, EN 50082-1), ECC directive LV 73/23 and 93/68 (EN 60730-1)

MEASUREMENT RANGE TABLE

PROBE	4 DIGIT	4 DIGIT with D.P.
tc J (J)	-200 ... 870 °C -328 ... 1598 °F 73 ... 1143 K	---
tc K (CrAl)	-200 ... 1370 °C -328 ... 2498 °F 73 ... 1643 K	---
tc R (r)	0 ... 1760 °C 32 ... 3200 °F 273 ... 2033 K	---
tc S (S)	-50 ... 1760 °C -58 ... 3200 °F 223 ... 2033 K	---

tc T (t)	-200 ... 400 °C -328 ... 752 °F 73 ... 673 K	---
RTD Pt100 IEC (Pt1, Pt2)	Pt1 -200 ... 850 °C -328 ... 1562 °F 73 ... 1123 K	Pt2 -99.9 ... 850.0 °C -99.9 ... 999.9 °F 73.0 ... 999.9 K
0/4 ... 20 mA, 0/1 ... 5 V, 0/2 ... 10 V (gener.)	-999 ... 9999	---

3 - INSTALLATION

MECHANICAL MOUNTING: The instrument, in DIN case 48 x 48 mm, is designed for panel mounting. Make an hole 45,5 x 45,5 mm and insert the instrument, fixing it with the provided special bracket. We recommend to mount the gasket to obtain an IP 54 front protection. Avoid to place the instrument in areas with humidity or dirt. Connect the instrument as far as possible from source of electromagnetic disturbances so as motors, power relays, relays, electrovalves, etc. The instrument is removable from its housing by the front side : is recommended to disconnect the power supply from the instrument when is necessary to do this operation.

ELECTRICAL CONNECTIONS: Carry out the electrical wiring connecting only one wire for each terminal, according to the following diagram, check that the power supply is the same as indicated on the instrument and the loads current is not upper than the maximum current admitted. The instrument, being a built in equipment with permanent connection into a cabinet, is not furnished with internal device protecting from overcurrent : it's recommended, therefore, to properly protect all the electric circuits connected to the instrument, with devices (ex. fuses) proportionate to the circulating currents. It's strongly recommended to use cables with proper insulation, according to the working voltages and temperatures. Furthermore, the input cable of the probe has to be kept separate from line voltage wiring. If the input cable of the probe is screened, it has to be connected on the ground with only one side. It is advisable to check that the parameters are those desired before connecting the outputs to the actuators so as to avoid malfunctioning. Whenever a failure of the instrument could cause dangerous or damaging situations, it should be kept in mind that the plant has to be provided with additional devices to ensure the safety.

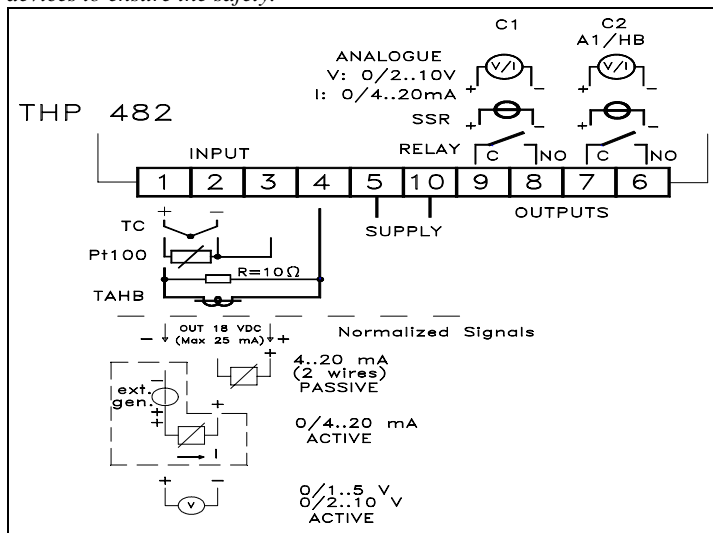

4 - OPERATING MODE

4.1 - CONFIGURATION OF THE MEASURE INPUT

The instruments configured in factory, with temperature sensor input, accept signals coming from thermocouples J, K, L, R, S, T and from thermoresistances Pt100 IEC. The choice between these kind of input types is possible by means of par. "SENs". As regard the instruments with normalised analogue signals input it's necessary instead to set, first of all, on par. "SCAL" the scale beginning used. Will be, then, programmed on the following parameter : for instruments with 0/4...20 mA input:

- "0_20" if it's desired to use the scale 0...20 mA

- "4_20" if it's desired to use the scale 4...20 mA

for instruments with 0/1...5 V or 0/2...10 V input:

- "0_5" if it's desired to use the scale 0...5 V or 0...10 V

- "1_5" if it's desired to use the scale 1...5 V or 2...10 V

It is necessary then to set on parameter "StrS" the value that the instrument has to visualise on the scale beginning (0/4 mA, 0/1V or 0/2V) and on parameter, "EndS" the value that the instrument has to visualise on the scale end (20 mA, 5V or 10V).

4.2 - ON/OFF CONTROL (C1)

The ON/OFF control mode acts setting parameter "Con1" = "OnOF" and works on C1 output depending on the set point ("SEtP"), on the functioning mode ("FunC") and on the hysteresis ("HSEt") programmed.

The instruments proceed with a ON/OFF regulation mode, with symmetric hysteresis. The regulator, therefore, behave in the following mode : in case of inverse action or heating mode ("HEAt"), deactivates C1 output when the temperature reaches the value [SEtP + HSEt] and than activates it again when temperature goes under the value [SEtP - HSEt] ; on the contrary, in case of direct action or cooling mode ("CooL"), deactivates C1 output when the temperature reaches the value [SEtP - HSEt] and than activates it again when temperature goes upper than the value [SEtP + HSEt].

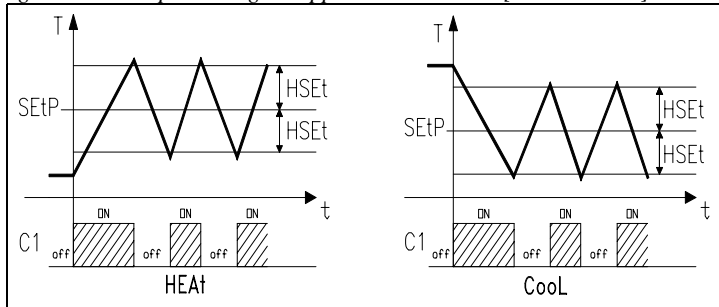

4.3 - SINGLE ACTION PID CONTROL (C1)

The PID single action regulation mode acts setting parameter "Con1" = "Pid" and works on C1 output depending on the set point ("SEtP"), on the functioning mode ("FunC") and on the control algorithm programmed. The PID algorithm of the instrument is provided to program the following parameters:

For PROPORTIONAL term :

"Pb" - Proportional Band,

"rS" - Manual reset

"tcr1" - Output C1 Cycle time

For INTEGRAL term:

"Int" - Integral time

For DERIVATIVE term:

"dEr" - Derivative time

4.4 - DOUBLE ACTION PID CONTROL (C1,C2)

This kind of action can happen only when the instrument has both regulation outputs (C1 and C2). In this case will not be visualised the "Con1" parameter, because the only possible regulation mode is PID double action. This kind of regulation is used to control installations where there's an element which causes a positive increment (ex. heater) and an element which causes a negative increment (ex. cooler). With "Func" parameter will be decided C1 output functioning, while C2 output will automatically works in the opposite way. For example, if "Func" = "HEAt" to C1 output will be connected the positive increment element (ex. heater) while to C2 output will be connected the negative increment element (ex. cooler). PID double action mode acts, therefore, on C1 and C2 outputs and depending on Set point ("SEt") and on control algorithm programmed. The PID algorithm of the instrument is provided to program the following parameters:

For PROPORTIONAL term :

"Pb" - Proportional Band,

"rS" - Manual reset

"tcr1" - Output C1 Cycle time

"tcr2" - Output C2 Cycle time

For INTEGRAL term:

"Int" - Integral time

For DERIVATIVE term:

"dEr" - Derivative time

Furthermore the parameter "Prat" (Power Ratio), on which it's necessary to set the ratio between power of the element controlled by C2 output and power of the element controlled by C1 output. If ever the parameter "Prat" is = 0, C2 output is deactivated and the regulator behave exactly as a PID single action, trough C1 output.

4.5 - AUTOTUNING FUNCTION

The instrument is set on parameters relative to PID control of standard value. If ever these should result to be unsuitable it would be advisable to program the AUTOTUNING function. The Autotuning function permits the automatic tuning of the PID instrument parameters, whether single or double action.

To active the AUTOTUNING function proceed as follows :

1) Set the desired "Set point".

2) Set, if present, "Con1" parameter = "Pid".

3) Set "Func" parameter depending on the process to be controlled, trough C1 output.

4) Connect the instrument with the plant

5) Set the parameter "Auto" as :

- "Sp" if it's desired to have autotuning on Set Point value programmed, or :

- "LoSp" if it's desired to have autotuning on a lower value (equal to 70% of Set Point programmed)

6) Go out of parameters programming

Now, the Autotuning function is activated and it's shown by the flashing of the two external decimal point on the lower display (SP). The regulator automatically tunes all the right parameters for a correct PID control mode. Before to switch off the instrument always wait for the end of the Autotuning process, indicated by the return of the display on the normal functioning. During the autotuning execution are activated some ON-OFF regulation cycles, that consequently make temperature swing abundantly around set point value (a bigger or smaller temperature swing depends on the process nature to be controlled and not on the instrument). If the process doesn't allow to big temperature variations upper than set point value, it's advisable to select autotuning cycle as "LoSP". The Autotuning procedure has been limited at a maximum time of 4 hours, after this time, if the Autotuning is not completed the instrument automatically get out from the procedure, showing constantly on the display "tout Auto". In case, instead, should happen an anomaly during autotuning, the instrument will visualise "no Auto" flashing. To stop the Autotuning cycle or re-establish the normal functioning after an error, switch off and on the instrument. The calculated values will be automatically memorised by the instrument at the end of the Autotuning cycle, in the PID control parameters.

4.6 - ANALOGUE CONTROL OUTPUTS (C1,C2)

In case that the control outputs (C1 and/or C2) are current or tension type it occurs to set on par. "Aout" the scale beginning used. Therefore, will be programmed on this parameter :

- "0" if it's desired to use the scale beginning equal to 0 (0 mA if the input is 0/4...20 mA, or 0V if the input is 0/2...10V)

- "no 0" if it's desired to use the scale beginning different from 0 (4 mA if the input is 0/4...20 mA, or 2 V if the input is 0/2...10V).

The output signal will be then proportional to the control power calculated by the instrument starting from 0% (output signal corresponding to the programmed beginning scale) till 100% (output signal corresponding to the maximum output end scale). The analogue outputs are used just in single or double action PID control type. When the control is ON/OFF type, the analogue output can assume only the control state 0% or 100%.

4.7 - ALARM OUTPUT OPERATING MODE (A1)

To configure the alarm functioning, whom activation is depending on the process value (A1), it's necessary to set "rLI" with a code made by 4 figures as following composed : a b c d where :

a : Alarm type

b : Alarm latch

c : Start-up behaviour

d : Output logic mode

a - ALARM TYPE: It's possible to have 6 different alarm output behaviours, depending on the value of the first code figure.

Note : Here following we'll indicate, in the examples, "ALn" to intend the A1 alarm. Furthermore, when it's programmed the window alarm type , instead of "ALn" will appear two parameters "ALnL" (Lower set) and "ALnH" (Higher set).

0 = ABSOLUTE MINIMUM ALARM: The alarm is activated when the process value goes under the alarm set programmed on "ALn" parameter.

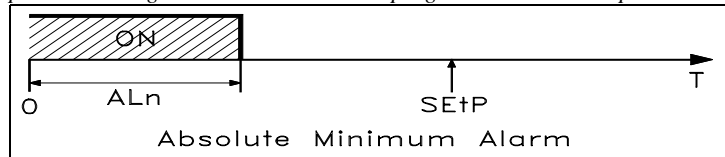

1 = ABSOLUTE MAXIMUM ALARM: The alarm is activated when the process value goes upper than the alarm set programmed on "ALn" parameter.



2 = ABSOLUTE WINDOW ALARM: The alarm is activated when the process value goes under the alarm set programmed on "ALnL" parameter or goes upper than the alarm set programmed on "ALnH" parameter.

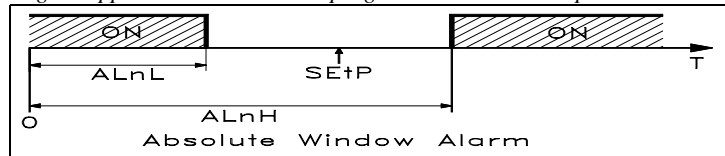

3 = RELATIVE MINIMUM ALARM: The alarm is activated when the process value goes under the value [SEtP - ALn].

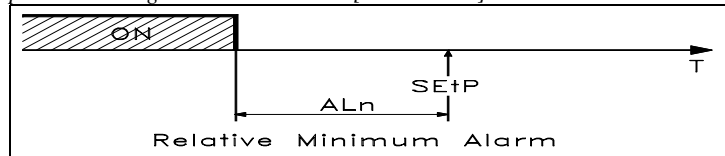

4 = RELATIVE MAXIMUM ALARM: The alarm is activated when the process value goes upper than the value [SEtP + ALn].



5 = RELATIVE WINDOW ALARM: The alarm is activated when the process value goes under the value [SEtP - ALnL] or goes upper than the value [SEtP + ALnH].

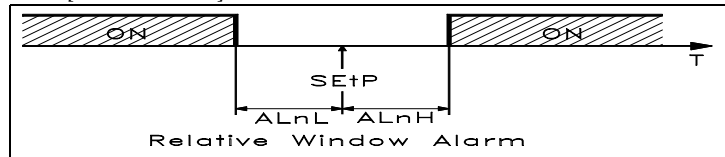

ALARMS HYSTERESIS: The alarms functioning depends furthermore on the alarms hysteresis ("HALn" parameter), which works in asymmetric mode. More precisely, in case of minimum alarm, the alarm will be activated when the process value goes under the alarm set and will be deactivated when it goes upper than the alarm set + "HALn"; in case of maximum alarm, the alarm will be activated when the process value goes upper than the alarm set and will be deactivated when it goes under the alarm set - "HALn". In case of window alarms, the minimum alarm example is applicable to the lowest set ("ALnL") while the maximum alarm example is applicable to the highest set ("ALnH").

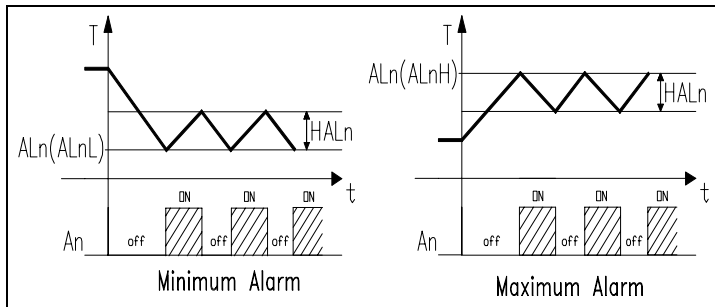

b - ALARM LATCH: It's possible to have 2 different alarm output behaviours, depending on the value of the second figure code.

0 = ALARM NOT LATCHED: The alarm remains active only in alarm conditions.

1 = ALARM LATCHED: The alarm is activated when there are alarm conditions and remains active although these conditions are not existing anymore, till is not pushed the "LEFT" key.

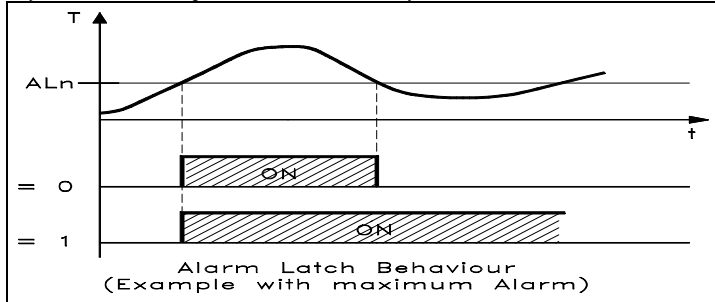

c - START-UP BEHAVIOUR: It's possible to have 2 different alarm output behaviours, depending on the value of the third figure code.

0 = NORMAL BEHAVIOUR: The alarm is always activated when there are alarm conditions.

1 = ALARM NOT ACTIVE AT START-UP: If at start-up the instrument is in alarm conditions this is not activated.

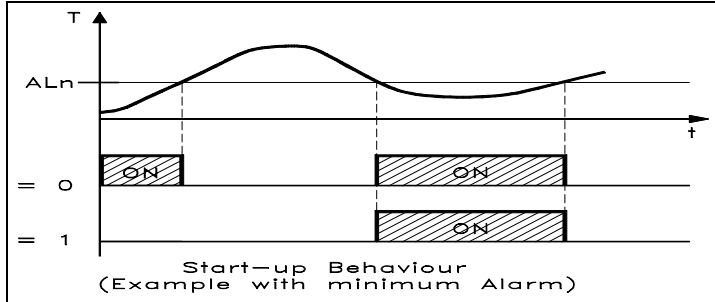

d - OUTPUT LOGIC MODE: It's possible to have 2 different alarm output behaviours, depending on the value of the fourth figure code.

1 = OUTPUT ON IN ALARM CONDITIONS: The output is activated when the alarm is active, while is deactivated while the alarm is not active.

0 = OUTPUT OFF IN ALARM CONDITIONS: The output is activated when the alarm is not active, while is deactivated while the alarm is active.

4.8 - HEATER BREAK ALARM FUNCTION (HB)

The instrument can be furnished with the Heater Break alarm function. (Alarm in case of broken heating element), in this case it will have an input (TAHB) able to measure the load current driven by C1 output. This kind of input accepts signals coming from current transformers (TA) till a maximum of 200 mA (at 200 mA the instrument measure a value of 100.0). Therefore, to obtain the correct Ampere measure it will occur that TA ratio would be 1/0,002. Tecnologic can supply 2 standard models : TR 03536 : 25A / 0,05 A, TR 03537 : 100 A / 0,2 A . During the functioning it's possible to visualise on SP display the current measured by TAHB input, expressed in Ampere (if obviously the TA ratio is 1/0,002) pushing "LEFT" key. The alarm will be active when, in C1output active conditions, the current measured by TAHB input will results lower than the value set on "ALHb" parameter. "ALHb" parameter has to be programmed with the value of the current normally taken over by the load driven by C1 output, considering as well the network tension fluctuations, in order to avoid undesired alarms. As regard the HB alarm hysteresis it's automatically calculated by the instrument as 2% of "ALHb" and the behaviour is the

same as a minimum alarm. If it's desired to deactivate the HB alarm, it's enough to program "ALHb" = 0.0.

It's possible to have 2 different HB alarm output behaviours, depending on the "rLHb" parameter programmed.

"nO" = NORMALLY OPENED: The output is activated when the alarm is active, while is deactivated when the alarm is not active.

"nC" = NORMALLY CLOSED: The output is activated when the alarm is not active, while is deactivated when the alarm is active.

Notes : In the connection of the Heater Break circuit it's necessary to introduce a resistance of 10 Ω (supplied with the instrument), connected in parallel with the current transformer, on the instrument terminals, as shown in drawing. When the instrument is equipped with the Heater Break function, the second output works whether as alarm output or as Heater Break alarm. Therefore, when it's desired to use the output as Heater Break alarm only, it's necessary to deactivate A1 alarm using "dALI" parameter. The current measure trough TAHB input needs at least 100 mS.

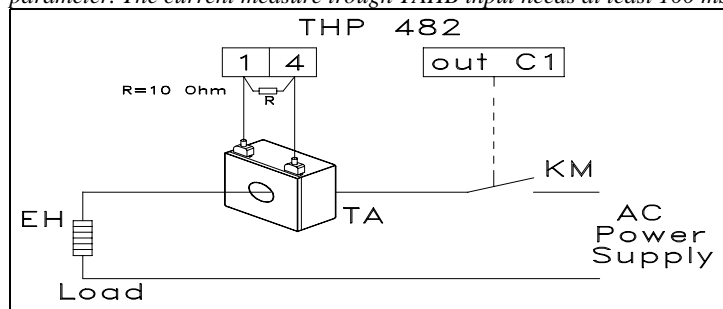

5 - PROGRAMMING

Push key "P" and keep it pushed for about 2 seconds, the instrument will show on the higher display PV the code of the first parameter ("SEtP") and on the lower display SP the programmed value with one figure flashing. This indicates that it's possible to modify it pushing "UP" key. When it's desired to modify a different figure it's necessary to select it, by means of "LEFT" key and then modify it using "UP" key. Once set the desired value pushing key "P" on the display will be shown the code of the next parameter. Working on "LEFT" and "UP" keys, as above described, is then possible to modify it. Once set the desired values push key "P" several times till the instrument goes out of the parameters programming, going back to the normal conditions of functioning visualising the process value on display PV and the Set Point value on display SP. Otherwise the instrument goes automatically out from the programming mode after about 50 seconds starting by the moment of the last push on the keys. The last parameter of the first level which appears on PV display is "PASS" : this is the request of the PASSWORD to accede to the second level parameters. To do this it's necessary to set, on Password request, the number written on the last page of this manual, and then push "P" key. If it's set the wrong Password the instrument goes out from the programming. The modality of programming of the second level parameters and the operations to go out by them are exactly the same as described for the first level parameters.

P.A.: During the instrument programming the regulation is not activated and the alarm outputs remain in the original conditions, as before the programming input. Always go out regularly from the programming phase because, if the instrument is switched-off during the programming, at the next switching-on will be signalised a memory error, visualised by the message "Err EEP". To re-establish the functioning is needed therefore to push, at the same time, "P" and "LEFT" keys and then get into the first level parameter programming, go out regularly, even if no parameters are changed. When programming operating parameters some parameters will not displayed, this happens because the instrument is predisposed to automatically not visualise the unnecessary parameters.

6 - DESCRIPTION OF PARAMETERS

Here following are described all the instrument parameters; pls. note that some of them could do not appear or because are according to the kind of used instrument or because are automatically not qualified, as they're not necessary.

FIRST LEVEL PARAMETERS

SEtP - SET POINT : Regulation value of Set Point

HSEt - SET POINT HYSTERESIS (ON/OFF CONTROL MODE) : Symmetric semi-band relative to the Set Point, which decides the C1

outputs activation and deactivation, when the regulation mode is ON/OFF. This parameter do appear just whether the programmed regulation is ON/OFF type ("Con1" = "OnOF").

PASS - PASSWORD REQUEST : Used to set the password that permits to accede to the second level parameters.

FIRST OR SECOND LEVEL PARAMETERS

The following parameters are normally present in the first level, but can be moved in the second level by means of parameter "ALPr" = "yES".

ALI - ALARM A1 THRESHOLD (MINIMUM OR MAXIMUM ALARM) : A1 alarm threshold for minimum or maximum alarms.

ALIL - MINIMUM ALARM A1 THRESHOLD (WINDOW ALARM) : A1 alarm threshold working as minimum alarm when it's set a window alarm type. **ALIH** - MAXIMUM ALARM A1 THRESHOLD (WINDOW ALARM) : A1 alarm threshold working as maximum alarm when it's set a window alarm type.

HALI - ALARM A1 HYSTERESIS : Asymmetric semi-band referred to A1 alarm value, that establish the deactivation value of A1 alarm.

ALHb - HEATER BREAK ALARM THRESHOLD : Activation set of Heater Break alarm.

SECOND LEVEL PARAMETERS

rLI - ALARM A1 OPERATION MODE : Permits to decide the alarm A1 functioning mode, trough the setting of a code, composed by 4 figures (see alarm output functioning).

rLHb - OUTPUT HB LOGIC MODE : Permits to establish the Heater Break alarm functioning mode, setting the output rest state ("nO" = normally opened, "nC" = normally closed)

FAIL - ALARM ON FOR ERROR INSTRUMENT : Permits to decide in which error conditions no alarm has to be activated ("no"), has to be activated A1 alarm ("rL1"), has to be activated A2 alarm ("rL2") or both ("rL12").

dALI - DISCONNECTION OF ALARM A1 : Permits to disable A1 alarm output ("yES"). Disabling the output, in alarm conditions, the alarm led will flash and the output will not be activated. Otherwise ("no") the output will function normally.

ALPr - ALARM PROGRAMMING AT FIRST OR SECOND LEVEL PARAMETERS : Permits to make visible the alarm setting parameters of the first ("no") or second ("yES") level.

SPLL - LOW/MINIMUM SET POINT : Minimum possible Set Point value or lower limit of Set point.

SPHL - HIGH/MAXIMUM SET POINT : Maximum possible Set Point value or higher limit of Set point.

Con1 - CONTROL MODE : Permits to select one of the possible regulation mode offered by the instrument : ON/OFF ("OnOF") or PID ("Pid"). This parameter is not visible in the instruments with 2 regulation outputs (C1 and C2) because in these models the only possible regulation is PID mode for both outputs.

Func - OUTPUT C1 OPERATING MODE : Permits to decide if C1 regulation mode has to control an Heating process ("HEAt") or a Cooling process ("CooL"). In the instruments with 2 regulation outputs (C1 and C2) this parameter automatically determines the C2 output opposite action to the one set at "Func" parameter.

Auto - AUTOTUNING : Parameter used to carry on an Autotuning cycle, that permits the automatic tune of the right PID regulation parameters. It's possible effect the Autotuning at the real Set Point value ("SP") or at a reduced value, equal to 70% of the Set Point ("LoSP"). If it's not desired to have the Autotuning, set "no".

Pb - PROPORTIONAL BAND : Band width around Set Point on which works the proportional regulation.

Int - INTEGRAL TIME : Integral time to be set in the PID regulation algorithm, expressed in seconds.

dEr - DERIVATIVE TIME : Derivative time to be set in the PID regulation algorithm, expressed in seconds.

tcr1 - OUTPUT C1 CYCLE TIME : Cycle time referred to C1 output, when intervenes the proportional regulation on PID regulation mode, expressed in seconds.

Prat - C2 / C1 POWER RATIO : Setting of power ratio between the element controlled by C2 output (ex. Cooler) and power of the element controlled by C1 output (ex. Heater) when the instrument has both C1 and C2 regulation outputs.

tr2 - OUTPUT C2 CYCLE TIME : Cycle time referred to C2 output , when intervenes the proportional regulation on PID regulation mode, expressed in seconds.

rS - MANUAL RESET : Proportional band positioning referred to the Set Point, expressed in percentage value.

Unit - UNIT OF MEASUREMENT : Permits to decide if the visualisation is expressed in Degree Centigrade ("C"), Fahrenheit ("F") or Kelvin ("AbS"). Pls. note : modifying this parameter results modified the display visualisation but not the Set Point and all the other parameters expressing the temperature values, and therefore they have to be manually modified. For example, if Set Point = 50°C and the unit of measurement is changed into °F, Set Point will be 50 °F.

SEnS - INPUT PROBE : Permits to select the kind of input probe : thermocouples J ("J"), K ("CrAl"), R ("r"), S ("S"), T ("t") or thermoresistances PT100 with no decimal point visualisation ("Pt1") or with decimal point visualisation ("Pt2").

SCAL - RANGE OF ANALOGUE INPUT FOR NORMALISED SIGNALS : Permits to determine the beginning scale input for normalised signals. For input 0/4..20 mA : if it's desired to use a scale 0..20 mA, program "0_20", if instead it's needed to use a scale 4..20 mA, program "4_20". For input 0/1..5 V or 0/2 V : if it's desired to use a scale 0..5 V or 0..10 V, program "0_5", if instead it's needed to use a scale 1..5 V or 2..10 V, program "1_5".

StrS - LOWER LIMIT OF ANALOGUE INPUT SCALE FOR NORMALISED SIGNALS : Value that the instrument has to visualise when on input it's present the minimum value measurable by the scale (0/4 mA, 0/1V or 0/2V).

EndS - HIGHER LIMIT OF ANALOGUE INPUT SCALE FOR NORMALISED SIGNALS : Value that the instrument has to visualise when on input it's present the maximum value measurable by the scale (20 mA, 5V or 10V).

Aout - ANALOGUE OUTPUTS RANGE : Permits to determine the scale beginning of the analogue outputs. On this par. will be then programmed : "0" if it's desired to use the beginning of the scale = 0 (0 mA, or 0V) or "no_0" if it's intended to use the beginning of the scale different from 0 (4 mA, 1V or 2V)

OFFt - CALIBRATION : Positive or negative Offset that is addicted to the probe detected value , first than the visualisation, on which is depending as well the functioning regulation. This parameter can be necessary to recalibrate the instrument.

FiLt - INPUT DIGITAL FILTER CONSTANT : Time constant of the software filter, referred to the input value measurement, expressed in seconds.

6.1 - PARAMETERS TABLES

FIRST LEVEL PARAMETERS TABLE

Par.	Description	Range	Def.	Notes
SEtP	Set point	SPLL ÷ SPHL	0	
HSEt	Set point hysteresis (ON/OFF control mode)	0 ... 9999 0.0 ... 999.9	1	
AL1	Alarm A1 threshold (minimum or maximum alarm)	-999 ... 9999 -99.9 ... 999.9	0	
AL1L	Minimum Alarm A1 threshold (window alarm)	-999 ... 9999 -99.9 ... 999.9	0	
AL1H	Maximum Alarm A1 threshold (window alarm)	-999 ... 9999 -99.9 ... 999.9	0	
HAL1	Alarm A1 hysteresis	0 ... 9999 0.0 ... 999.9	1	
ALHb	Heater Break alarm threshold	0.0 ... 100.0	0	
PASS	Password request second level programming parameters	0000 ... 9999		

SECOND LEVEL PARAMETERS TABLE

Par.	Description	Range	Def.	Notes
rL1	Alarm A1 operation mode	0000 ... 5111	0000	
rLHb	Output HB logic mode	nO - nC	nO	
FAIL	Alarm on for error instrument	rL1 - rL2 rL12 - no	no	
dAL1	Disconnection of alarm A1	no / yES	no	

ALPr	Alarm programming at first or second level parameters	no / yES	no	
SPLL	Low/minimum Set Point	-999 ... SPHL -99.9 ... SPHL	-999	
SPHL	High/maximum Set point	SPLL ... 9999 SPLL ... 999.9	9999	
Con1	Control mode	Pid / OnOF	Pid	
Func	Output C1 operating mode	HEAt / CooL	HEAt	
Auto	Autotuning	no / SP / LoSP	no	
Pb	Proportional band	1 ... 9999	100	
Int	Integral time	0 ... 9999 sec.	500	
dEr	Derivative time	0 ... 9999 sec.	30	
tr1	Output C1 cycle time	1 ... 255 sec.	30	
Prat	C2 / C1 power ratio	0.0 ... 999.9	1.0	
tr2	Output C2 cycle time	1 ... 255 sec.	30	
rS	Manual reset	-100.0 ... 100.0 %	50	
Unit	Unit of measurement	C / F / AbS	C	
SEnS	Input probe	J / CrAl / r / S / t Pt1 / Pt2	J	
SCAL	Range of analogue input for normalized signals	0_20 / 4_20 0_5 / 1_5	0_20 0_5	
StrS	Lower limit of analogue input scale for normalized signals	-999 ... 9999	0	
EndS	Higher limit of analogue input scale for normalized signals	-999 ... 9999	0	
Aout	Analogue outputs range	0 / no_0	0	
OFFt	Calibration	-999 ... 9999 -99.9 ... 999.9	0	
FiLt	Input digital filter constant	0 ... 20 sec.	1	

7 - PROBLEMS, MAINTENANCE AND WARRANTY

ERRORS SIGNALLING : The 2 displays are used as well to visualise anomaly conditions of instrument functioning :

- In case of probe interruption it's visualised "- - - -" flashing.
- In case the measured variable goes under the probe limits it's visualised "uuuu" flashing.

- In case the measured variable goes upper under the probe limits it's visualised "oooo" flashing.

In these cases verify the correct connection of the probe with the instrument and afterward proceed to verify the probe itself.

- In case the Autotuning has been interrupted by an anomaly (probe interruption, etc.) it's visualised "no Auto" flashing.

- In case the Autotuning is not ended within 4 hours, it's visualised "tout Auto" flashing.

- If the instrument has been switched-off during the programming, at the next switching-on will be signalised the eeprom memory error, appearing the message "Err EEPr". To re-establish the right functioning it's necessary to push contemporary the "P" and "LEFT" keys and then get into parameter programming of the first level, go out regularly, even if no parameters are changed.

All the anomaly conditions will de-active all the regulation outputs.

HOW TO CLEAN: We recommend to avoid abrasive cleaners or containing solvents which could damage the instrument.

WARRANTY AND REPAIRS: The instrument is under warranty against construction vices or defected material, noticed within 12 months from delivery date. The warranty is limited to the repairs or to the substitution of the instrument. The eventual opening of the housing, the violation of the instrument or the wrong use and installation of the product means the automatically decay of the warranty. In case of defected instrument, noticed in warranty period or out of warranty, do contact our sales department to obtain the shipment authorisation. The defected product must be shipped to TECNOLOGIC with the detailed description of the failures found and without any fees or charge for Tecnologic, safe different agreements.

THP482 PASSWORD = 0381