

TLK 38 S

MICROPROCESSOR-BASED DIGITAL ELECTRONIC CONTROLLER



OPERATING INSTRUCTIONS Vr. 01 (ENG) - 07/05 - cod.: ISTR 06862

TECNOLOGIC S.p.A.

VIA INDIPENDENZA 56
27029 VIGEVANO (PV) ITALY

TEL.: +39 0381 69871

FAX: +39 0381 698730

internet : <http://www.tecnologic.it>

e-mail: info@tecnologic.it

FOREWORD



This manual contains the information necessary for the product to be installed correctly and also instructions for its maintenance and use; we therefore recommend that the utmost attention is paid to the following instructions and to save

it. This document is the exclusive property of TECNOLOGIC S.p.A. which forbids any reproduction and divulgation, even in part, of the document, unless expressly authorized.

TECNOLOGIC S.p.A. reserves the right to make any formal or functional changes at any moment and without any notice.

Whenever a failure or a malfunction of the device may cause dangerous situations for persons, things or animals, please remember that the plant has to be equipped with additional devices which will guarantee safety.

Tecnologic S.p.A. and its legal representatives do not assume any responsibility for any damage to people, things or animals deriving from violation, wrong or improper use or in any case not in compliance with the instrument's features.

INDEX

- 1 **INSTRUMENT DESCRIPTION**
 - 1.1 GENERAL DESCRIPTION
 - 1.2 FRONT PANEL DESCRIPTION
- 2 **PROGRAMMING**
 - 2.1 FAST PROGRAMMING OF SET POINTS
 - 2.2 PARAMETER PROGRAMMING
 - 2.3 PARAMETER PROTECTION USING THE PASSWORD AND PARAMETER PROGRAMMING LEVELS
- 3 **INFORMATION ON INSTALLATION AND USE**
 - 3.1 PERMITTED USE
 - 3.2 MECHANICAL MOUNTING
 - 3.3 ELECTRICAL CONNECTIONS
 - 3.4 ELECTRICAL WIRING DIAGRAM
- 4 **FUNCTIONS**
 - 4.1 MEASURING AND VISUALIZATION
 - 4.2 ON/OFF CONTROL
 - 4.3 REACHING OF "SP1" SET POINT AT CONTROLLED SPEED (RAMP)
 - 4.4 DELAY OUTPUTS FUNCTIONS
 - 4.5 PARAMETERS CONFIGURATION BY KEY01
- 5 **PROGRAMMABLE PARAMETERS TABLE**
- 6 **PROBLEMS, MAINTENANCE AND GUARANTEE**
 - 6.1 ERROR SIGNALLING
 - 6.2 CLEANING
 - 6.3 GUARANTEE AND REPAIRS
- 7 **TECHNICAL DATA**
 - 7.1 ELECTRICAL DATA
 - 7.2 MECHANICAL DATA
 - 7.3 MECHANICAL DIMENSIONS, PANEL CUT-OUT AND MOUNTING
 - 7.4 FUNCTIONAL DATA
 - 7.5 MEASUREMENT RANGE TABLE
 - 7.6 INSTRUMENT ORDERING CODE

1 - INSTRUMENT DESCRIPTION

1.1 - GENERAL DESCRIPTION

TLK 38 S is a digital microprocessor-based controller, with ON/OFF control. The process value is visualized on 4 red displays, while the output status is indicated by 2 LED displays. The instrument is equipped with a 3 LED programmable shift indexes and can have up to 2 outputs: relay type or can drive solid state relays type (SSR).

Depending on the model required the input accept:

C: Thermocouples temperature probes (J,K,S and TECNOLOGIC IRS Infrared sensors), mV signals (0..50/60 mV, 12..60 mV), Thermoresistances PT100.

E: Thermocouples temperature probes (J,K,S and TECNOLOGIC IRS Infrared sensors), mV signals (0..50/60 mV, 12..60 mV), Thermistors PTC and NTC.

I: normalized analogue signals 0/4..20 mA

V: normalized analogue signals 0..1 V, 0/1..5 V, 0/2..10 V

1.2 - FRONT PANEL DESCRIPTION

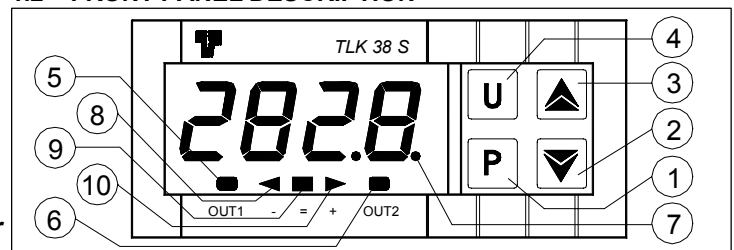

1 - Key P: This is used to access the programming parameters and to confirm selection.

2 - Key DOWN: This is used to decrease the values to be set and to select the parameters. If the key is held down, the user returns to the previous programming level until he exits the programming mode.

3 - Key UP: This is used to increase the values to be set and to select the parameters. If the key is held down, the user returns to

the previous programming level until he exits the programming mode.

4 - Key U : It can be used to modify the visibility of the parameters in programming mode (see par. 2.3).

5 - Led OUT1 : indicates the state of output OUT1

6 - Led OUT2 : indicates the state of output OUT2

7 - Led SET : It indicates access to the programming mode and parameter programming level.

8 - Led - Shift index: indicates that the process value is lower than [SP1-AdE].

9 - Led = Shift index: indicates that the process value is within the range [SP1+AdE ... SP1-AdE]

10 - Led + Shift index: indicates that the process value is higher than [SP1+AdE].

2 - PROGRAMMING

2.1 - FAST PROGRAMMING OF SET POINTS

Push key "P", then release it and the display will visualise "SP 1" alternatively to the programmed value.

To modify the value, press "UP" key to increase it or the "DOWN" key to decrease it.

These keys change the value one digit at a time but if they are pressed for more than one second, the value increases or decreases rapidly and, after two seconds in the same condition, the changing speed increases in order to allow the desired value to be reached rapidly.

Set Point "SP1" can be programmed with a value that is between the value programmed on par. "SPL1" and the one programmed on par. "SPH1".

Once the desired value has been reached, by pushing key P it is possible to exit by the fast programming mode, or (if the instrument have 2 outputs) it is possible to visualise and modify the Set point "SP2" like "SP1".

Set Point "SP2" can be programmed with a value that is between the value programmed on par. "SPL2" and the one programmed on par. "SPH2".

To exit the fast Set programming it is necessary to push key P, after the visualisation of the last Set Point, or alternatively, if no key is pressed for approx. 15 seconds, the display will return to normal functioning automatically.

2.2 - PARAMETERS PROGRAMMING

To access the instrument's function parameters, press the key P and keep it pressed for about 5 seconds, after which the display will visualised the code that identifies the first parameter.

Using the UP and DOWN keys, the desired parameter can be selected and pressing the P key, the display will alternately show the parameter code and its setting that can be changed with the UP and DOWN keys.

Once the desired value has been set, press the key P again: the new value will be memorised and the display will show only the code of the selected parameter.

Pressing the UP and DOWN keys, it is possible to select another parameter and change it as described.

To exit the programming mode, do not press any key for about 20 seconds, or keep the UP or DOWN key pressed until it exits the programming mode.

2.3 - PARAMETER PROTECTION USING THE PASSWORD AND PARAMETER PROGRAMMING LEVELS

The instrument has a parameter protection function using a password that can be personalised, through the "PASS" parameter.

If one wishes to have this protection, set the password number desired in the parameter "PASS".

When the protection is working, press the P key to access the parameters and keep it press for about 5 seconds, after which the display will show the par. "r.PAS".

At this point, press P and the display will show "0".

Using the UP and DOWN keys, set the password number programmed and press the key "P".

If the password is correct, the display will visualise the code that identifies the first parameter and it will be possible to programme the instrument in the same ways described in the previous section.

Protection using a password can be disabled by setting the parameter "PASS" = OFF.

The password protection hides all the configuration parameters behind a factory set password to avoid unwanted changes being made to the programming of the controller. To make a parameter accessible without having to enter a password follows this procedure.

Enter the programming using the Password and select the parameter which is desired to be accessible with no password protection. Once the parameter has been selected, if the SET led is off, this means that the parameter is programmable by entering the password (it's then "protected") if it's instead on, this means the parameter is programmable without password (not protected).

If you want to change the accessibility of the parameter push U key and keep it pressed for approx.1 sec : SET led will change its state indicating the new access level of the parameter (on= not protected; off=protected).

In case some parameters are no longer protected, when one tries to have access at the programming, the display will show all the parameters not protected and the par. "r.PAS" (through which will be possible to have access to the "protected" parameters.)

Note: *If the Password gets lost, just cut off the supply, push P key and keeping it pressed for 5 seconds whilst switching on the supply to the instrument.*

In this way it's possible to have access to all the parameters, verify and modify the par. "PASS".

3 - INFORMATION ON INSTALLATION AND USE



3.1 - PERMITTED USE

The instrument has been projected and manufactured as a measuring and control device to be used according to EN61010-1 for the altitudes operation until 2000 ms.

The use of the instrument for applications not expressly permitted by the above mentioned rule must adopt all the necessary protective measures.

The instrument CANNOT be used in dangerous environments (flammable or explosive) without adequate protection.

The installer must ensure that EMC rules are respected, also after the instrument installation, if necessary using proper filters.

Whenever a failure or a malfunction of the device may cause dangerous situations for persons, thing or animals, please remember that the plant has to be equipped with additional devices which will guarantee safety.

3.2 - MECHANICAL MOUNTING

The instrument, in case 33 x 75 mm, is designed for flush-in panel mounting.

Make a hole 29 x 71 mm and insert the instrument, fixing it with the provided special bracket.

We recommend that the gasket is mounted in order to obtain the front protection degree as declared. Avoid placing the instrument in environments with very high humidity levels or dirt that may create condensation or introduction of conductive substances into the instrument.

Ensure adequate ventilation to the instrument and avoid installation in containers that house devices which may overheat or which may cause the instrument to function at a higher temperature than the one permitted and declared.

Connect the instrument as far away as possible from sources of electromagnetic disturbances such as motors, power relays, relays, solenoid valves, etc.

3.3 - ELECTRICAL CONNECTION

Carry out the electrical wiring by connecting only one wire to each terminal, according to the following diagram, checking that the power supply is the same as that indicated on the instrument and that the load current absorption is no higher than the maximum electricity current permitted.

As the instrument is built-in equipment with permanent connection inside housing, it is not equipped with either switches or internal devices to protect against overload of current: the installation will include an overload protection and a two-phase circuit-breaker, placed as near as possible to the instrument, and located in a position that can easily be reached by the user and marked as instrument disconnecting device which interrupts the power supply to the equipment.

It is also recommended that the supply of all the electrical circuits connected to the instrument must be protected properly, using devices (ex. fuses) proportionate to the circulating currents.

It is strongly recommended that cables with proper insulation, according to the working voltages and temperatures, be used.

Furthermore, the input cable of the probe has to be kept separate from line voltage wiring. If the input cable of the probe is screened, it has to be connected to the ground with only one side.

Whether the instrument is 12 V version it's recommended to use an external transformer TCTR, or with equivalent features, and to use only one transformer for each instrument because there is no insulation between supply and input.

We recommend that a check should be made that the parameters are those desired and that the application functions correctly before connecting the outputs to the actuators so as to avoid malfunctioning that may cause irregularities in the plant that could cause damage to people, things or animals.

3.4 - ELECTRICAL WIRING DIAGRAM

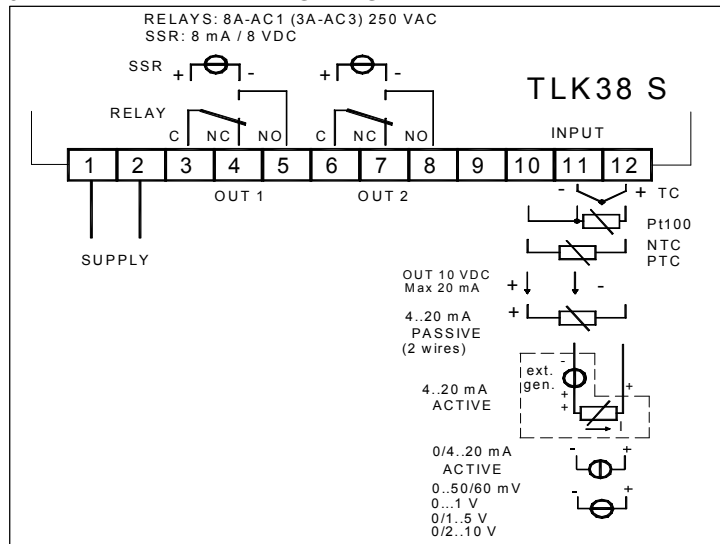

4 - FUNCTIONS

4.1 - MEASURING AND VISUALIZATION

Depending on the model required the input accept:

C: Thermocouples temperature probes (J,K,S and TECNOLOGIC IRS Infrared sensors), mV signals (0..50/60 mV, 12..60 mV), Thermoresistances Pt100.

E : Thermocouples temperature probes (J,K,S and TECNOLOGIC IRS Infrared sensors), mV signals (0..50/60 mV, 12..60 mV), Thermistors PTC and NTC.

I : normalized analogue signals 0/4..20 mA

V : normalized analogue signals 0..1 V, 0/1..5 V, 0/2..10 V

Depending on the model, using par. "SEnS", it's possible to select the type of input probe, which can be :

- for thermocouples J (J), K (CrAl), S (S) or for infrared sensors serie TECNOLOGIC IRTC1 with linearization J (Ir.J) or K (Ir.CA)
- for thermoresistances Pt100 IEC (Pt1) or thermistors PTC KTY81-121 (Ptc) or NTC 103AT-2 (ntc)
- for normalised signals in current 0..20 mA (0.20) or 4..20 mA (4.20)

- for normalised signals in tension 0..1 V (0.1), 0..5 V (0.5), 1..5 V (1.5), 0..10 V (0.10) or 2..10 V (2.10).

- for normalised signals in tension 0..50 mV (0.50), 0..60 mV (0.60), 12..60 mV (12.60).

We recommend to switch on and off the instrument when these parameters are modified, in order to obtain a correct measuring.

For the instruments with input for temperature probes (tc, rtd) it's possible to select, through par. "Unit", the unit of measurement (°C, °F) and, through par. "dP" (Pt100, PTC and NTC only) the desired resolution (0=1°; 1=0,1°).

Instead, with regards to the instruments with normalised analogue input signals, it is first necessary to program the desired resolution on par. "dP" (0=1; 1=0,1; 2=0,01; 3=0,001) and then, on par. "SSC", the value that the instrument must visualise at the beginning of the scale (0/4 mA, 0/12 mV, 0/1 V o 0/2 V) and, on par. "FSC", the value that the instrument must visualise at the end of the scale (20 mA, 50 mV, 60 mV, 5 V or 10 V).

The instrument allows for measuring calibration, which may be used to recalibrate the instrument according to application needs, by using par. "OFSt" and "rot".

Programming par. "rot"=1,000, in par. "OFSt" it is possible to set a positive or negative offset that is simply added to the value read by the probe before visualisation, which remains constant for all the measurements.

If instead, it is desired that the offset set should not be constant for all the measurements, it is possible to operate the calibration on any two points.

In this case, in order to decide which values to program on par. "OFSt" and "rot", the following formulae must be applied :

$$\text{"rot"} = (D2-D1) / (M2-M1) \quad \text{"OFSt"} = D2 - (\text{"rot"} \times M2)$$

where:

M1 =measured value 1

D1 = visualisation value when the instrument measures M1

M2 =measured value 2

D2 = visualisation value when the instrument measures M2

It then follows that the instrument will visualise :

$$DV = MV \times \text{"rot"} + \text{"OFSt"}$$

where: DV = visualised value MV= measured value

Example 1: It is desired that the instrument visualises the value effectively measured at 20° but that, at 200°, it visualises a value lower than 10° (190°).

Therefore : M1=20 ; D1=20 ; M2=200 ; D2=190

$$\text{"rot"} = (190 - 20) / (200 - 20) = 0,944$$

$$\text{"OFSt"} = 190 - (0,944 \times 200) = 1,2$$

Example 2: It is desired that the instrument visualises 10° whilst the value actually measured is 0°, but, at 500° it visualises a 50° higher value (550°).

Therefore : M1=0 ; D1=10 ; M2=500 ; D2=550

$$\text{"rot"} = (550 - 10) / (500 - 0) = 1,08$$

$$\text{"OFSt"} = 550 - (1,08 \times 500) = 10$$

By using par. "FIL" it is possible to program time constant of the software filter for the input value measured, in order to reduce noise sensitivity (increasing the time of reading).

In the event of probe error, it is possible to set the instrument so that the outputs OUT1 and OUT2 continues to work in cycles according to the times programmed in the parameter "ton1" - "ton2" (activation times) and "toF1" - "toF2" (deactivation times).

If an error occurs on the probe the instrument activates the relative output for the time "ton", then deactivates it for the time "toF" and so on whilst the error remains.

Programming "ton" = OFF the output in probe error condition will remain switched off.

Programming instead "ton" to any value and "toF" = OFF the output in probe error condition will remain switched on.

4.2 - ON/OFF CONTROL

The instrument carries out an ON/OFF control with asymmetrical hysteresis.

This type of control works on the output OUT1 and OUT2, depending on the measure, on the Set Points "SP1" and "SP2", on the functioning modes "Fun1" and "Fun2", and on the hysteresis "HSE1" and "HSE2".

The controls works in the following way : in the case of reverse action, or heating ("Fun"=HEAt), it deactivates the output, when the process value reaches [SP] and is then activated again when the process value goes below value [SP - HSE].

Vice versa, in case of direct action or cooling ("Fun"=CooL), it deactivates the output, when the process value reaches [SP] in and

		ntc= thermistor NTC 103-AT2 0.20= 0..20 mA 4.20= 4..20 mA 0.1= 0..1 V 0.5=0..5 V 1.5= 1..5 V 0.10= 0..10 V 2.10= 2..10 V	0.1 / 0.5 / 1.5 / 0.10 / 2.10		
9	SSC	Low scale limit in case of input with V / I signals	-1999 ÷ FSC	0	
10	FSC	High scale limit in case of input with V / I signals	SSC ÷ 9999	100	
11	dP	Number of decimal figures	Pt1 / Ptc / ntc: 0 / 1 norm sig.: 0 ÷ 3	0	
12	Unit	Temperature unit of measurement	°C / °F	°C	
13	FiL	Input digital filter	OFF ÷ 20.0 sec.	1.0	
14	OFSt	Measuring Offset	-1999 ÷ 9999	0	
15	rot	Rotation of the measuring straight line	0.000 ÷ 2.000	1.000	
16	ton1	Activation time output OUT1 for probe broken	OFF ÷ 99.59 min.sec	OFF	
17	toF1	Deactivation time output OUT1 for probe broken	OFF ÷ 99.59 min.sec	OFF	
18	ton2	Activation time output OUT2 for probe broken	OFF ÷ 99.59 min.sec	OFF	
19	toF2	Deactivation time output OUT2 for probe broken	OFF ÷ 99.59 min.sec	OFF	
20	Fun1	Functioning mode OUT1: HEAt= Heating (reverse) CoolL= Cooling (direct)	HEAt / CoolL	HEAt	
21	Fun2	Functioning mode OUT2: see "Fun1"	HEAt / CoolL	HEAt	
22	HSE1	Hysteresis OUT1	OFF ÷ 9999	1	
23	HSE2	Hysteresis OUT2	OFF ÷ 9999	1	
24	Ptd1	OUT1 delay	OFF ÷ 99.59 min.sec	OFF	
25	Ptd2	OUT2 delay	OFF ÷ 99.59 min.sec	OFF	
26	PtS1	OUT1 delay after switch off	OFF ÷ 99.59 min.sec	OFF	
27	PtS2	OUT2 delay after switch off	OFF ÷ 99.59 min.sec	OFF	
28	od	Outputs Delay at power on	OFF ÷ 99.59 min.sec	OFF	
29	SLor	Gradient of SP1 ramp: InF= Ramp not active	0.00 ÷ 99.99 / InF unit/min.	InF	
30	AdE	Shift value for the shift index functioning	OFF...9999	5	
31	PASS	Access Password to parameter functions	OFF ÷ 9999	OFF	
32	r.PAS	Access Password Request	-1999 ÷ 9999		

6 - PROBLEMS, MAINTENANCE AND GUARANTEE

6.1 - ERROR SIGNALLING

Error	Reason	Action
----	Probe interrupted	Verify the correct connection between probe and instrument and then verify the correct functioning of the probe
uuuu	The measured variable is under the probe's limits (under-range)	
oooo	The measured variable is over the probe's limits (over-range)	
ErEP	Possible anomaly of the EEPROM memory	Push key "P"

6.2 - CLEANING

We recommend cleaning of the instrument with a slightly wet cloth using water and not abrasive cleaners or solvents which may damage the instrument.

6.3 - GUARANTEE AND REPAIRS

The instrument is under warranty against manufacturing flaws or faulty material, that are found within 12 months from delivery date. The guarantee is limited to repairs or to the replacement of the instrument. The eventual opening of the housing, the violation of the instrument or the improper use and installation of the product will bring about the immediate withdrawal of the warranty's effects. In the event of a faulty instrument, either within the period of warranty, or further to its expiry, please contact our sales department to obtain authorisation for sending the instrument to our company. The faulty product must be shipped to TECNOLOGIC with a detailed description of the faults found, without any fees or charge for Tecnologic, except in the event of alternative agreements.

7 - TECHNICAL DATA

7.1 - ELECTRICAL DATA

Power supply: 12 VAC/VDC, 24 VAC/VDC, 100.. 240 VAC +/- 10%

Frequency AC: 50/60 Hz

Power consumption: 4 VA approx.

Input/s: 1 input for temperature probes: tc J,K,S ; infrared sensors TECNOLOGIC IRS J e K; RTD Pt 100 IEC; PTC KTY 81-121 (990 Ω @ 25 °C); NTC 103AT-2 (10KΩ @ 25 °C) or mV signals 0...50 mV, 0...60 mV, 12 ...60 mV or normalized signals 0/4...20 mA, 0..1 V, 0/1...5 V , 0/2...10 V.

Normalized signals input impedance: 0/4..20 mA: 51 Ω; mV and V: 1 MΩ

Output/s: Up to 2 outputs. Relay SPDT (8 A-AC1, 3 A-AC3 / 250 VAC) ; or in tension to drive SSR (8mA/ 8VDC).

Auxiliary supply output: 12 VDC / 20 mA Max.

Electrical life for relay outputs: 100000 operat.

Installation category: II

Measurement category: I

Protection class against electric shock: Class II for Front panel

Insulation:

Reinforced insulation between the low voltage part (Supply L or H and relay outputs) and front panel; Reinforced insulation between the low voltage section (Supply L or H and relay outputs) and the extra low voltage section (input, SSR outputs); Reinforced between power supply and relays; No insulation between supply 12 V and input. No insulation between input and SSR outputs.

7.2 - MECHANICAL DATA

Housing: Self-extinguishing plastic, UL 94 V0

Dimensions: 33 x 75 mm, depth 64 mm

Weight: 110 g approx.

Mounting: Flush in panel in 29 x 71 mm hole

Connections: 2,5 mm² screw terminals block

Degree of front panel protection : IP 65 mounted in panel with gasket

Pollution situation: 2

Operating temperature: 0 ... 50 °C

Operating humidity: 30 ... 95 RH% without condensation

Storage temperature: -10 ... +60 °C

7.3 - MECHANICAL DIMENSIONS, PANEL CUT-OUT AND MOUNTING [mm]

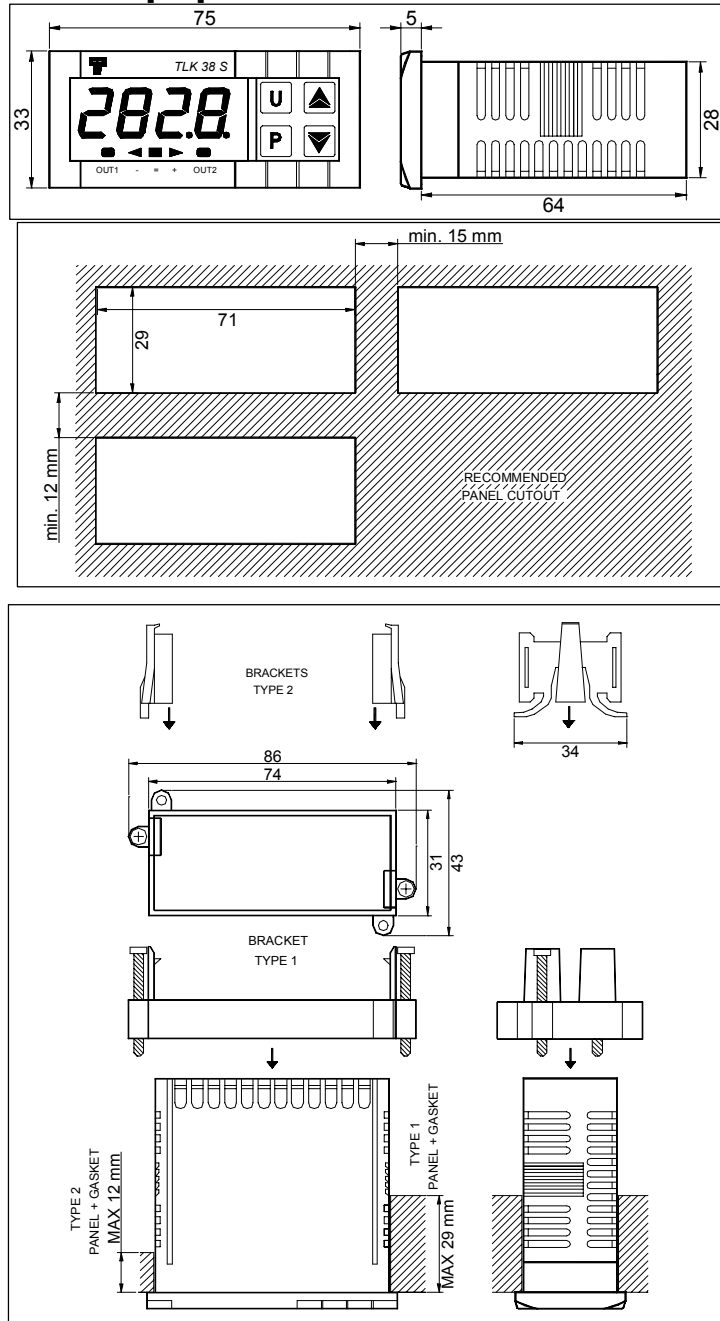

7.4 - FUNCTIONAL FEATURES

Control: ON/OFF

Measurement range: according to the used probe (see range table)

Display resolution: according to the probe used 1/0,1/0,01/0,001

Overall accuracy: +/- (0,5 % fs + 1 digit) ; tc S: +/- (1 % fs + 1 digit)

Max cold junction compensation drift (in tc) : 0,1 °C/°C with operating temperature 0 ... 50 °C after warm-up of 20 min.

Sampling rate: 130 ms.

Display: 4 Digit Red h 12 mm

Compliance: ECC directive EMC 89/336 (EN 61326), ECC directive LV 73/23 and 93/68 (EN 61010-1)

Approvals: C-UL (file n. E206847)

7.5 - MEASURING RANGE TABLE

INPUT	"dP" = 0	"dP" = 1, 2, 3
tc J "SEnS" = J	0 ... 1000 °C 32 ... 1832 °F	----
tc K "SEnS" = CrAI	0 ... 1370 °C 32 ... 2498 °F	----

tc S "SEnS" = S	0 ... 1760 °C 32 ... 3200 °F	----
Pt100 (IEC) "SEnS" = Pt1	-200 ... 850 °C -328 ... 1562 °F	-199.9 ... 850.0 °C -199.9 ... 999.9 °F
PTC (KTY81-121) "SEnS" = Ptc	-55 ... 150 °C -67 ... 302 °F	-55.0 ... 150.0 °C -67.0 ... 302.0 °F
NTC (103-AT2) "SEnS" = ntc	-50 ... 110 °C -58 ... 230 °F	-50.0 ... 110.0 °C -58.0 ... 230.0 °F
0..20 mA "SEnS" = 0.20		
4..20 mA "SEnS" = 4.20		
0 ... 50 mV "SEnS" = 0.50		
0 ... 60 mV "SEnS" = 0.60		-199.9 ... 999.9
12 ... 60 mV "SEnS" = 12.60	-1999 ... 9999	-19.99 ... 99.99
0 ... 1 V "SEnS" = 0.1		-1.999 ... 9.999
0 ... 5 V "SEnS" = 0.5		
1 ... 5 V "SEnS" = 1.5		
0 ... 10 V "SEnS" = 0.10		
2 ... 10 V "SEnS" = 2.10		

7.6 - INSTRUMENT ORDERING CODE

TLK38 a b c d ee S

a : POWER SUPPLY

F = 12 VAC/VDC

L = 24 VAC/VDC

H = 100... 240 VAC

b : INPUT

C = thermocouples (J, K, S, I.R.), mV, thermoresistances (Pt100)

E = thermocouples (J, K, S, I.R.), mV, thermistors (PTC, NTC)

I = normalized signals 0/4..20 mA

V = normalized signals 0..1 V, 0/1..5 V, 0/2..10 V.

c : OUTPUT OUT1

R = Relay

O = VDC for SSR

d : OUTPUT OUT2

R = Relay

O = VDC for SSR

- = None

ee : SPECIAL CODES