

# The Sollatek FreoCom

Microprocessor-controlled thermostat and voltage protector

User guide

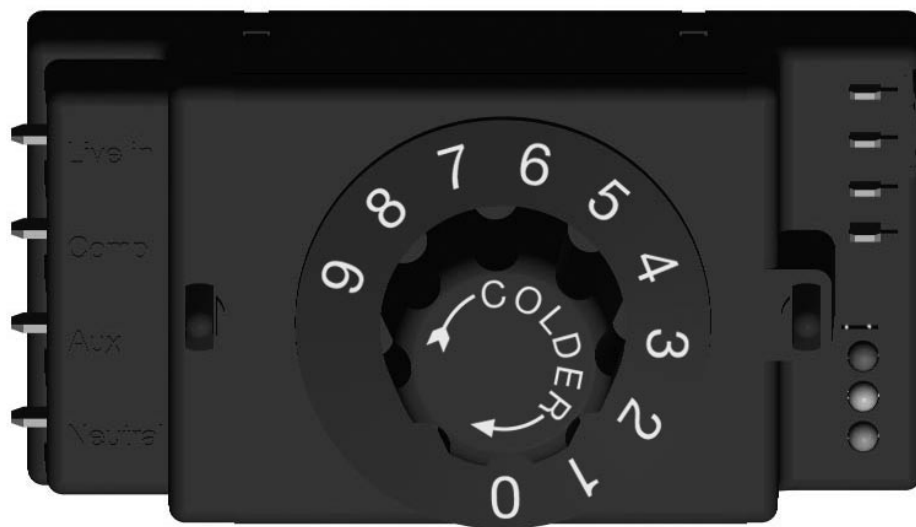

*Sollatek*<sup>TM</sup>

## 1. Introduction

The FreoCom has the option of controlling three separate outputs (compressor, Aux1 and Aux2). Refer to Section 8 "Connections to FreoCom" for more details on the usage of different outputs.

The FreoCom provides very accurate temperature control to your refrigeration appliance, timed defrost control and protects

equipment by disconnecting the mains supply when it goes either below or above pre-set acceptable limits. It provides reliability and immunity from environmental factors such as humidity and altitude. These factors make the FreoCom the total solution for all refrigeration equipment.

## 2. Overview

### 2.1 Overall view

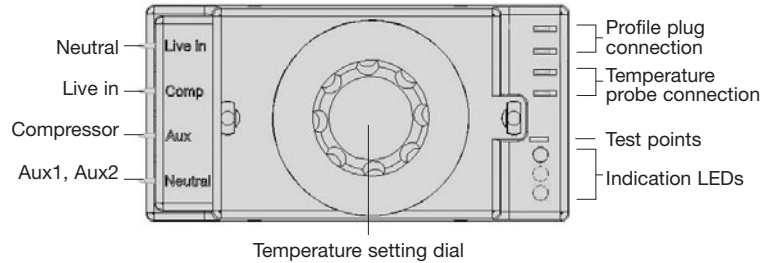

### 2.2 LEDs description

R	LEDs Y G	Mains Voltage on	Compressor on	Description
●	○ ○	✓	×	Off. Voltage bad (too high or too low).
○	● ○	✓	×	Wait period. (Intelligent Time Delay). Allows neutralisation of refrigerant pressure.
○	○ ●	✓	✓	On. Voltage good. No wait time. Cooling demand.
●	○ ●	✓	×	Defrost Period. Starts after 7 hours of accumulated compressor run time for a specified time.
⊗	○ ○	×	×	No cool demand (NCD). Voltage is bad.
○	⊗ ○	✓	×	No cool demand (NCD). Wait is on.
○	○ ⊗	✓	×	No cool demand (NCD). In cut-out zone.
⊗	⊗ ⊗	△		Test mode. If in the No cool demand (NCD), this forces compressor to go on for 10 seconds
○	⊗ ⊗	△	×	Probe fault. Normally compressor shuts down unless specified by customer to cycle with pre-determined time sequence.
⊗	⊗ ○	△	×	Fault. Mains sense auto recovery possible.
⊖	⊖ ⊖	△	×	Knob in off position.

**KEY:** ✓ On/good. × Off/bad. △ Not relevant ⊗ Flashing ⊖ Cycling ○ Off ● On

## 3. Temperature control

The FreoCom has a microprocessor-based temperature controller utilising one NTC (Negative Temperature Coefficient) probe. The cooler temperature is determined by measuring the temperature of either the return airflow or evaporator temperature depending on where the customer prefers to fit

the probe. The cooler set temperature is achieved by setting the potentiometer fitted in front of the FreoCom unit, taking the required differential into consideration. For further information please refer to the comprehensive diagram found on the middle pages pages.

## 4. Timed defrost control

The FreoCom is equipped with the facility to perform Timed Defrost Function. This would simply disconnect the compressor after a number of hours of compressor operation and for a predetermined duration. For example, after 12 hours of accumulated operation of the compressor, the defrost cycle will be entered into for 45 minutes. If the second output is utilised

then during this period this relay can be energised, making it ideal for controlling a reversing fan motor or a defrost heater. If the third output is utilised this will go off automatically as the compressor is off. For further information please refer to the comprehensive diagram found on the middle pages.

## 5. Voltage protection

The FreoCom continually senses the mains supply and will disconnect the compressor (and Aux1, Aux2 if fitted) when the mains voltage is either higher or lower than acceptable limit. The FreoCom reconnects the mains voltage automatically after the supply returns and remains

within normal limits (between High Voltage and Low Voltage reconnect voltages) for a pre-set time delay.

For further information please refer to the comprehensive diagram found on the middle pages.

## 6. Features

### 6.1 Temperature blind time

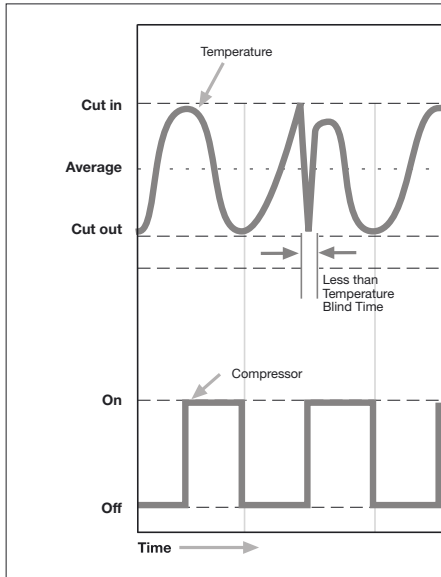

The software will ignore the sensor temperature reading for the first few seconds (a pre-set value of 10 seconds) after the compressor is switched on. This is to prevent short-term thermal effects such as those caused by the fan starting to operate causing disconnection.

### 6.2 High voltage and low voltage blind time

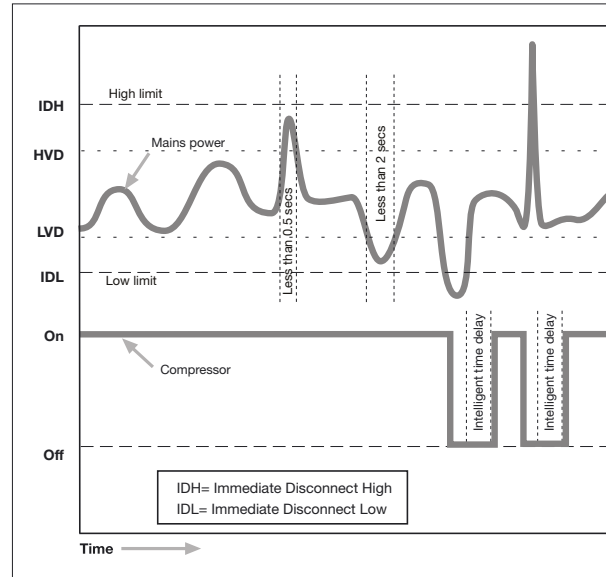

The software permits high and low mains voltages transitions for short periods of time preventing inadvertent compressor stop-starts. Preset values of 0.5 and 2 seconds respectively are employed. However, if the mains voltage goes higher or lower than set extreme limits, then the FreoCom will immediately disconnect the outputs. The low extreme limit is set at 75/83/150V, while the high extreme limit is set at 150/165/300V for 115/127/230V voltage systems.

### 6.3 Temperature dial 'off' position

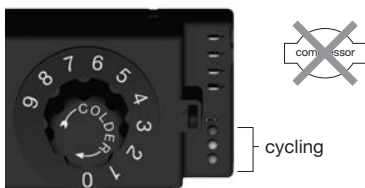

The control knob on the FreoCom can be set to the 'Off' position. This is achieved by turning the temperature probe fully anti-clockwise as shown above. This setting turns the compressor (and Aux1, Aux2 if fitted) off regardless of temperature, allowing manual defrost, cleaning etc. The outputs are enabled when the dial position is changed.

### 6.4 Test mode

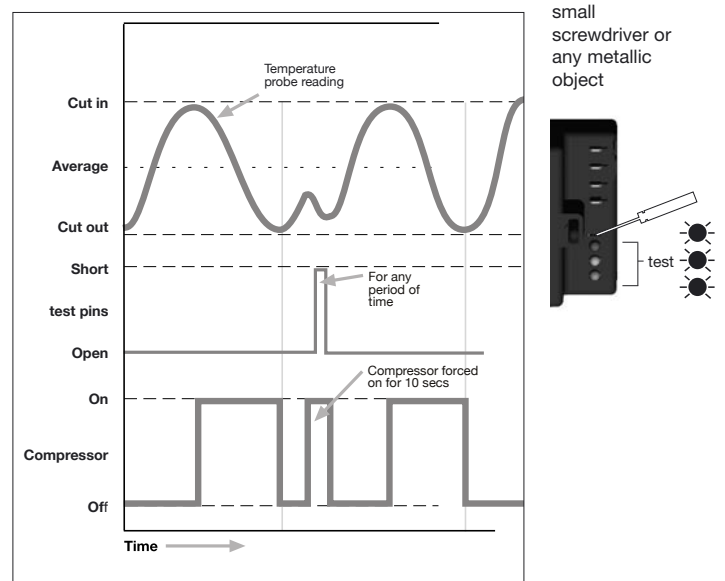

This is a useful feature during production or after sales service avoiding the necessity of bypassing the FreoCom. The test mode allows the technician to turn on the compressor for 10 seconds even though the cooler is at the required temperature. This is achieved by shorting the two test pins using a screwdriver or any other metallic object as shown.

## 6. Features (continued)

### 6.5 Intelligent Time Delay

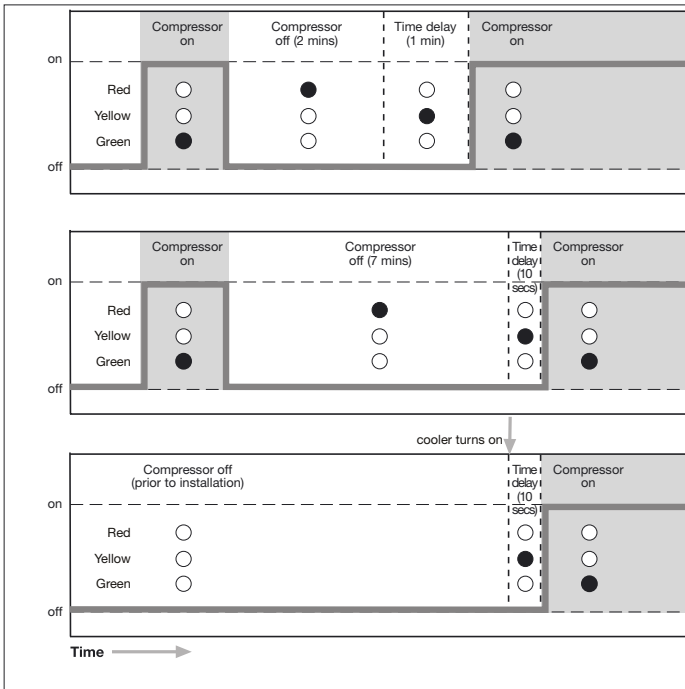

The FreoCom has a built-in intelligent time delay of up to 3 minutes (customer-specified). Depending on the disconnection period, the intelligent time delay is automatically adjusted by the FreoCom. For example, a 1 minute disconnection will result in only a 2 minute additional delay, making the total delay three minutes. Any disconnection of 3 minutes or over will only result in a 10-second delay.

The time delay is essential in allowing compressor gases to neutralise, ensuring that the mains has stabilised before re-connection and avoiding a locked rotor condition.

## 7. Alarms and errors

### 7.1 Frequency monitoring and error detection

The assumption is that cooling demand is on throughout the period

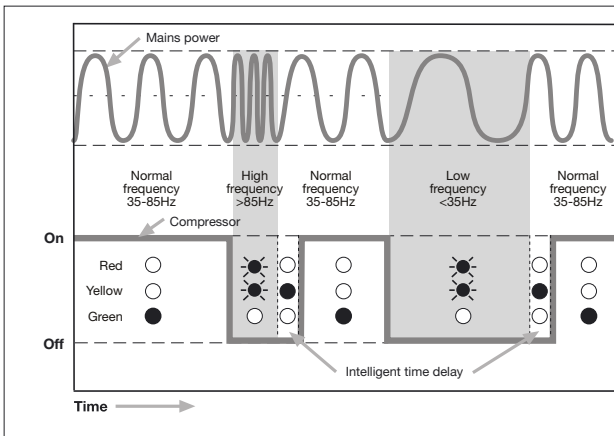

The FreoCom dynamically measures the frequency of the mains supply and reacts accordingly. If the mains supply frequency is too low or too high, the FreoCom will then disconnect the compressor (and Aux1, Aux2 if fitted) and indicate an error signal through the LEDs.

The FreoCom has the ability to auto recover once the frequency is within acceptable limits.

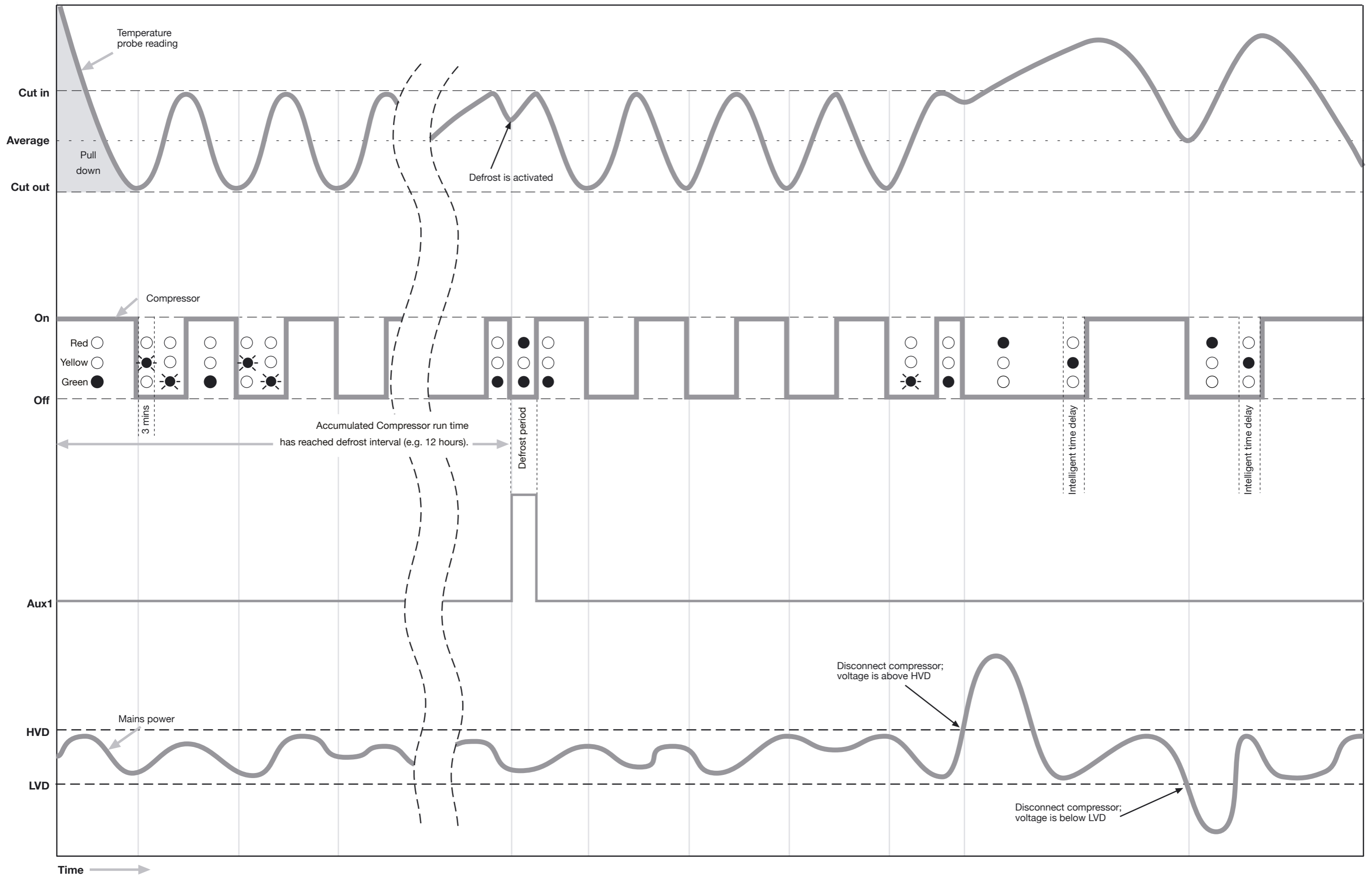

Note: Aux2 is not shown in the above diagram as it switches on and off the same way the compressor does.

## 7. Alarms and errors (continued)

### 7.2 Temperature probe error detection

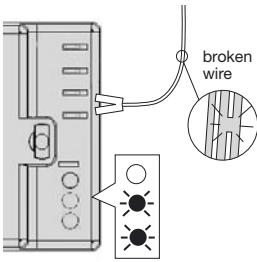

The FreoCom will report an error code through the LEDs indicating an external sensor fault if it happens. Depending on customer preference, the FreoCom will either:

1. Disconnect the load(s) and auto recovers once the problem clears; or
2. Cycle the compressor On and Off for pre-set periods regardless of the cooler temperature; or
3. Show the error signal through the LEDs.

The FreoCom recovers from this routine once the problem no longer exists.

#### Scenario: detect fault and disconnect

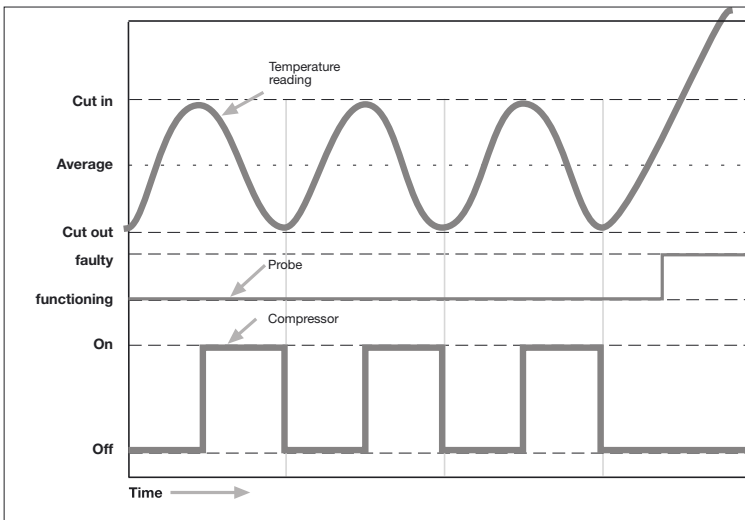

#### Scenario: detect fault and cycle

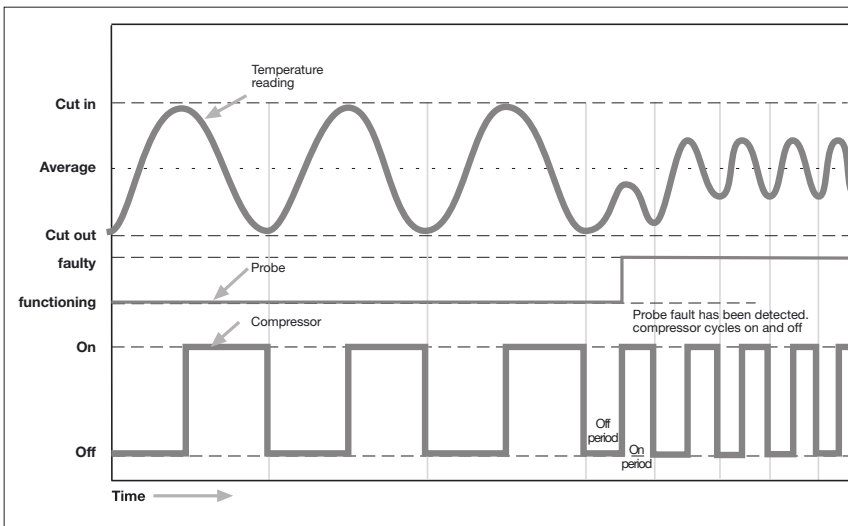

### 7.3 Internal fault detection

If an internal fault within the FreoCom is detected and reported through the LEDs, then the most likely action would be to replace the unit. In some instances, the fault may automatically clear and the FreoCom auto-recovers and returns to normal run mode.

## 8. Installation Guide

The FreoCom is fully encapsulated, designed mainly for OEM (Original Equipment Manufacturer) applications and rated at 16Amps. These devices are encapsulated to hermetically seal and ruggedise them. They have five right-angled spade terminals labeled Neutral, Live in, Comp, Aux1 and Aux2, and also two pairs of 0.11" vertical spade terminals labeled Temp probe and Temp profile. All these terminals are suitable for push-on crimps.

### Connections to the FreoCom

- Mains power (or utility power) connections are made using standard 0.25" right-angled crimp terminals marked Neutral, Live in and Comp, and standard 0.11" right-angled crimp terminals marked Aux1 and Aux2.
- Mains Live and Neutral should be connected to Live in and Neutral terminals respectively.
- The compressor live should be connected to Comp terminal.
- The auxiliary output from the Freo, labeled Aux1 is used to drive a reverse fan during defrost (or could be specified to drive other application such as a defrost heater or lights in a different behavior if required).
- The auxiliary output from the Freo, labeled Aux2, is also provided. This output is used to drive a forward fan (or any other application if required), which can go on only when the compressor is on.
- In addition, there is provision for the connection of a thermal sensor (provided). Depends on the cooler manufacturer, the sensor probe should be mounted either inside the evaporator or within the cooled cabinet, in the airflow from the cabinet into the evaporator, to ensure that the sensor measures the temperature of the airflow over the product. At the other end of this cable is a pair of crimp receptacles, which should be fitted into the FreoCom crimp terminals labeled Temp probe.
- On first switching on there will be no output for the duration of the wait time. As the FreoCom has intelligent delay time, it will re-connect the power within 10 seconds if it has been off for more than the required delay time of 3 minutes. As the FreoCom monitors the cabinet temperature and input voltage, the LEDs will light as shown in section 2.2 (LEDs description).

### Testing Procedure

As the FreoCom is made up of three main functions, Thermostatic Control, Timed Defrost Control and Voltage Protection, these can be tested separately.

A) To test the Thermostatic function - ensure that the incoming voltage is within acceptable limits.

*Note: Refer to the separate technical datasheet for the values of cut-in and cut-out temperatures.*

1. Install the FreoCom in the cooler as described above. Adjust the temperature setting knob so that marking "9" is facing downward. Connect the cooler to a source of variable AC voltage such as a Variac. Adjust the output of the Variac to a good starting voltage (110-115V or 220-230V). The YELLOW LED will light. It will flash if the cabinet temperature detected by the sensor is below cut-in temperature. Otherwise it will remain illuminated constantly for the duration of the wait period.
2. After a maximum of three minutes, the FreoCom will connect the mains supply to the compressor (assuming the temperature in the cabinet is above cut-in temperature).

(TIP \*\* The FreoCom has two special test pins. By shorting these pins with a conducting object, the 3-minute delay is bypassed and the FreoCom will energise immediately.)

3. With the compressor running, turn the temperature knob fully anti-clockwise (or until "0" marking is facing downward). The compressor will be disconnected. Return the knob to its previous position (marking "9" is facing downward). The FreoCom will enter 3-minute wait state before reconnecting the compressor. Again you can use the test pins to by-pass the wait delay.
4. Once the cabinet has reached the desired temperature (or when the temperature is below cut-out temperature) and the incoming voltage is within acceptable limits, the FreoCom will disconnect the compressor and the YELLOW LED will flash (which indicates incoming voltage is good and compressor satisfied).
5. If the incoming voltage is dropped until it is below acceptable level (186V for 220/230V), the FreoCom will now move to Flashing RED LED (which indicates incoming voltage is BAD and compressor satisfied). As the cabinet temperature rises and the incoming voltage remains BAD, the RED LED will become constant (which indicates incoming voltage is BAD and compressor NOT satisfied).

B) To test the timed defrost function – ensure that the incoming voltage is within the acceptable limits.

*Note: Since it will take a long time for the defrost function to be tested in real time, this procedure is produced to simulate the defrost operation and test the defrost application (whether it is a reverse fan or a defrost heater).*

1. Install the FreoCom in the cooler as described above. Adjust the temperature setting knob so that marking "0" is facing downward. Connect the cooler to a source of variable AC voltage such as a Variac. Adjust the output of the Variac to a good starting voltage (110-115V or 220-230V). All the LEDs will lit for half a second and then only the GREEN LED will become on alone.
2. Wait for about a second and then turn the knob clockwise so that marking "4" is now facing downward (or until the YELLOW LED becomes on alone).
3. Wait for about a second, turn the knob anti-clockwise so that marking "2" is now facing downward (or until the RED LED is now on alone).
4. Wait for another second and turn the knob clockwise so that marking "8" is now facing downward (or until all the LEDs are now on at the same time).
5. Wait for a second and then turn the knob so that marking "8" is NO LONGER facing downward.
6. The reverse fan (or the defrost heater) will come on immediately and both the RED and the GREEN LEDs are now on at the same time.

## 8. Installation Guide (continued)

C) To test the voltage function - first ensure that the thermostat knob on the Freo-Com is set so that marking "9" is facing downward while the LEDs are facing right and the Live terminals are facing left.

*Note: The below-mentioned voltage limits are for a standard unit. Refer to the separate technical datasheet for these limits if the unit is not standard.*

1. Connect the FreoCom to a variable power source (e.g. Variac) and ensure the output of the Variac is at a good starting voltage (i.e. between 110-115V or 220-230V). The YELLOW LED is ON
2. Wait for about 3 minutes. The FreoCom will energise the load and the Green LED is now ON. (TIP \*\* The FreoCom has two special test pins. By shorting these pins with a conducting object, the 3-minute delay is bypassed and the FreoCom will energise immediately.)
3. Slowly decrease the voltage until the RED LED comes on while the GREEN LED is still on. Wait for 2 seconds (this is the Under Voltage Blind Time), the FreoCom will then disconnect the compressor and the RED LED will come on alone. This should happen at about 90V for the 115V model and 180V for the 230V model. This is the Low Voltage Disconnect.
4. Increase the voltage slowly (in 1 volt increments) until the YELLOW LED lights. This is the Low Voltage Reconnection voltage (93V for the 115V and 186V for the 230V model). WAIT for 3 minutes. The GREEN LED will light.
5. Repeat the above process for the Over-Voltage. The Over Voltage Disconnect should be 133V for the 115V model and 266V for the 230V models.
6. To check for the over-voltage reconnect, drop the voltage until the YELLOW LED lights (130V for the 115V models and 260V for the 230V models). This is the Over Voltage Reconnect. WAIT for 3 minutes. The GREEN LED will light.

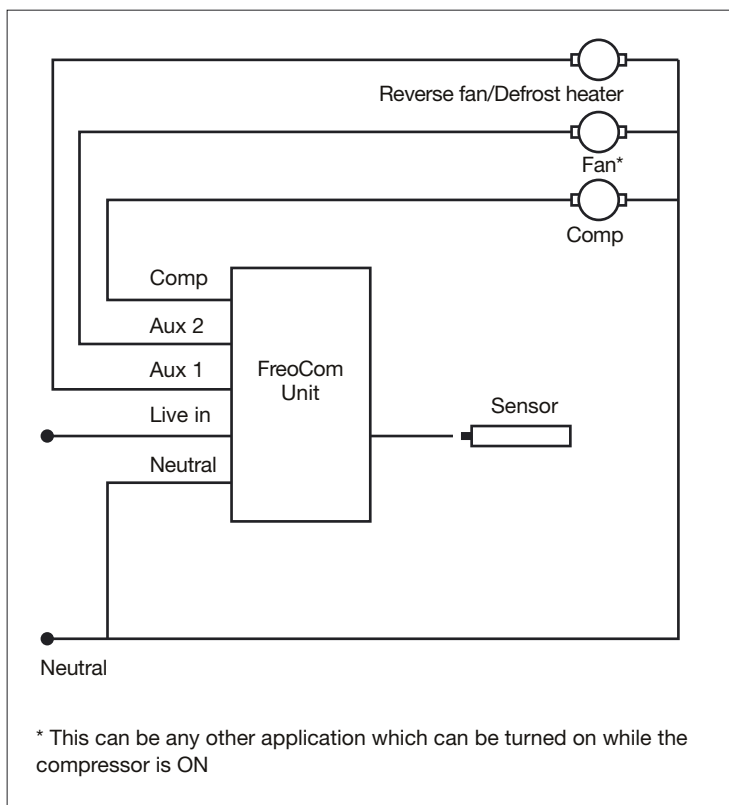

## 9. Mechanical drawings

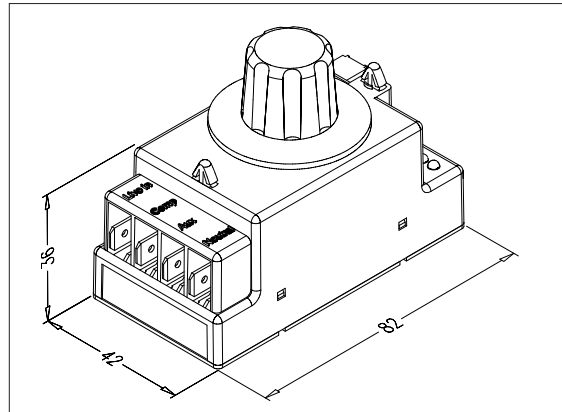
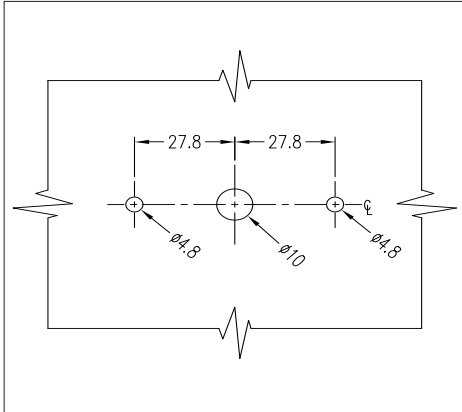

## 10. Specifications

Control	Microprocessor
Temperature Control	Available (1)
Defrost Control	Timed (1)
Voltage Protection	Available (1)
Output - Compressor	16A 250VAC 70A Inrush Current @240VAC 140A Inrush Current @120VAC 0.75HP @ 120VAC 1.5HP @ 240VAC 4000 VA Breaking Capacity
Output - Aux1, Aux2	6A 250VAC 40A Inrush Current @240VAC 80A Inrush Current @120VAC 0.125HP @ 120VAC 0.25HP @ 240VAC 1500 VA Breaking Capacity
Working Frequency	Auto-sense 50/60Hz
Surge Protection	6.5kA
Power Connections	0.25" spade terminals suitable for push-on crimps
Environmental	Sealed and protected against water, humidity, dust and insects
Unit Dimensions (mm)	80 x 42 x 60
Unit Weight	100gms
Temperature Probe Type	Negative Temperature Coefficient (NTC)
Temperature Probe Length	1 meter (different lengths available)
Packing Specifications	Supplied in a carton containing 100 units
Carton Dimensions (cm)	53 x 44 x 28
Carton Weight	11.5Kgms
Cartons per Pallet	10 (or 1000 units per pallet)
Pallet Dimensions (cm)	120 x 100 x 90
Pallet Weight	130Kgms

(1) Please refer to the unit separate technical sheet for further details on the exact figures.

*Note: All the mentioned values throughout sections 3 to 7 can be customer specified.*

---

SOLLATEK UK LTD,  
UNIT 10 POYLE 14 INDUSTRIAL ESTATE NEWLANDS DRIVE, POYLE, SLOUGH SL3 0DX, UK

**Tel:** International +44 1753 688300    **Fax:** International +44 1753 685306

**E-mail:** [sales@sollatek.com](mailto:sales@sollatek.com)    [www.sollatek.com](http://www.sollatek.com)

Specifications are subject to change without prior notice.

©Sollatek (UK) Limited 1996 All Rights Reserved.

SOLLATEK and the SOLLATEK device are the trade marks of the Sollatek group of companies. Revision 2.0 July 04 Stock No. 74120306

The Power to Protect