

TLY 29

MICROPROCESSOR-BASED DIGITAL ELECTRONIC FREEZER CONTROLLER OPERATING INSTRUCTIONS



Shown with optional metallic bezel and Blue LED

CONTROLTEC

8 Four Coins Drive
Canonsburg, PA 15317
1-800-566-3883
724-746-1901

www.controlteconline.com

TECHNOLOGIC

FOREWORD

This manual contains the information necessary for the product to be installed correctly and also instructions for its maintenance and use; we therefore recommend that the utmost attention is paid to the following instructions.

Though this manual has been issued with the greatest care, CONTROLTEC will not take any responsibility deriving from its use. The same applies to each person or Company involved in the issuing of this manual.

This document is the exclusive property of CONTROLTEC which forbids any reproduction and distribution of the document, in whole or in part, unless expressly authorized.

CONTROLTEC reserves the right to make any formal or functional changes without any notice.

INDEX

- 1 INSTRUMENT DESCRIPTION**
 - 1.1 GENERAL DESCRIPTION
 - 1.2 FRONT PANEL DESCRIPTION
- 2 PROGRAMMING**
 - 2.1 PROGRAMMING OF SET POINT
 - 2.2 PARAMETER PROGRAMMING
 - 2.3 PARAMETER PROTECTION USING THE PASSWORD
 - 2.4 PARAMETER PROGRAMMING LEVELS
 - 2.5 ACTIVE SET POINT SELECTION
 - 2.6 ON / STAND-BY FUNCTION
 - 2.7 CLOCK PROGRAMMING
- 3 INFORMATION ON INSTALLATION AND USE**
 - 3.1 PERMITTED USE
 - 3.2 MECHANICAL MOUNTING
 - 3.3 ELECTRICAL CONNECTIONS
 - 3.4 ELECTRICAL WIRING DIAGRAM
- 4 FUNCTIONS**
 - 4.1 MEASURING AND VISUALIZATION
 - 4.2 OUTPUTS CONFIGURATION
 - 4.3 TEMPERATURE CONTROL
 - 4.4 CONTINUOUS CYCLE FUNCTION (BLAST CHILL)
 - 4.5 COMPRESSOR PROTECTION FUNCTION AND DELAY AT POWER-ON
 - 4.6 DEFROST CONTROL
 - 4.7 MANUAL DEFROST
 - 4.8 EVAPORATOR FANS CONTROL
 - 4.9 ALARM FUNCTIONS
 - 4.9.1 TEMPERATURE ALARMS
 - 4.9.2 EXTERNAL ALARM
 - 4.9.3 OPEN DOOR ALARM
 - 4.10 DIGITAL INPUT
 - 4.11 AUXILIARY OUTPUT
 - 4.12 FUNCTION OF "U" AND "DOWN/AUX" KEYS
 - 4.13 PARAMETER CONFIGURATION BY KEY01
- 5 PROGRAMMABLE PARAMETERS TABLE**
- 6 PROBLEMS , MAINTENANCE AND GUARANTEE**
 - 6.1 SIGNALLING
 - 6.2 CLEANING
 - 6.3 GUARANTEE AND REPAIRS
- 7 TECHNICAL DATA**
 - 7.1 ELECTRICAL DATA
 - 7.2 MECHANICAL DATA
 - 7.3 MECHANICAL DIMENSIONS, PANEL CUT-OUT AND MOUNTING
 - 7.4 FUNCTIONAL DATA
 - 7.5 INSTRUMENT ORDERING CODE

1 - INSTRUMENT DESCRIPTION

1.1 - GENERAL DESCRIPTION

The model TLY 29 is a microprocessor based digital controller that is typically used in cooling applications that have temperature control with ON/OFF regulation and defrosting control with set hour intervals (Real Time Clock Defrosting) by means of electrical heating or hot gas/reverse cycle.

The instrument has 3 relay outputs, two inputs for PTC or NTC temperature probes and a digital input. All can be user configured.

The 3 outputs can be used for controlling the compressor or the temperature control device (OUT), the defrosting device (DEF), the evaporation fan (FAN) or used to control an auxiliary device (AUX) or an alarm (AL).

The two inputs for the PTC or NTC temperature probes can be used to measure the cabinet temperature (Pr1) and the evaporator temperature (Pr2) while the digital input (DIG) can be programmed to carry out various functions such as defrosting commands, selecting a different temperature set point, external alarm signals, activating a continuous cycle, activating an auxiliary output, etc.

The instrument is equipped with 4 program keys, a 4-digit display and 9 LED indicator lights; an optional internal buzzer is available to signal alarms.

Other important characteristics of the instrument are: program protection using personalized password, turning the instrument on and off (stand-by) using the "U" key, configuration of parameters via the KEY 01 device, alternating between two sets of temperature control schemes and more.

1.2 - FRONT PANEL DESCRIPTION

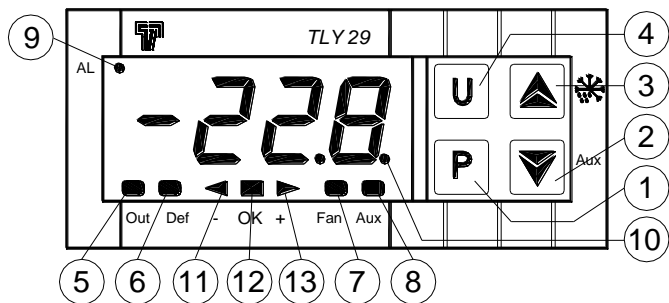

1 - Key P : Used for setting the Set point and for programming the function parameters

2 - Key DOWN/Aux: Used for decreasing the set point value and for selecting the parameters. It can also be programmed via the parameter "Fbd" to carry out other functions such as activating the Aux output, initiating a continuous cycle, selecting the active set point or turning the device on and off (stand-by) (see par. 4.12).

3 - Key UP/DEFROST: Used for increasing the set point value, for selecting the parameters and for activating manual defrosting.

4 - Key U: Used for seeing the temperatures of the cabinet and evaporator probes (Pr1 and Pr2) and the internal clock (if present). It can also be programmed via the parameter "USrb" to carry out other functions, just like the key DOWN/AUX (see par. 4.12).

5 - Led OUT: Indicates the compressor output status (or the temperature control device) on (on), off (off) or inhibited (flashing)

6 - Led DEF: Indicates defrosting in progress (on) or dripping (flashing).

7 - Led FAN: Indicates fan output status on (on), off (off) or delayed after defrosting (flashing)

8 - Led AUX: Indicates AUX output status on (on), off (off) or inhibited (flashing)

9 - Led AL: Indicates the alarm status (on), off (off) and silenced or memorized (flashing)

10 - Led SET: Indicates the user is in programming mode and the programming level of the parameters. It also serves to indicate the Stand-by status.

11 - Led - : Indicates that a low temperature alarm is in progress (lit) or that a low temperature alarm has been memorized (flashing).

12 - Led OK: Indicates that no alarms are in progress

13 - Led +: Indicates that a high temperature alarm is in progress (lit) or that a high temperature alarm has been memorized (flashing).

2 - PROGRAMMING

2.1 - PROGRAMMING OF THE SET POINT

Press the key **P** then release it and the display will show **SP 1** (or **SP 2** if the second set is active at that time) alternating with the set point value (see selection of the active set point).

To change press the UP key to increase the value or DOWN to decrease it.

These keys increase or decrease the value one digit at a time, but if the button is pressed for more than one second the value increases or decreases faster, and after two seconds, the speed increases to its fastest level to reach desired values rapidly.

Exiting the Set mode is achieved by pressing the P key or if no key is pressed for 15 seconds the display automatically returns to the normal function mode.

2.2 - PARAMETERS PROGRAMMING

To access the instrument's function parameters, press the **P** key and keep it pressed for about 5 seconds, after which the SET led will light up, the display will show the code that identifies the first group of parameters ("SP"). Use the UP and DOWN keys to reach the group heading of parameters that are to be edited. Once the group of parameters has been selected, press the P and the code that identifies the first parameter in that group will be displayed.

Again, using the UP and DOWN keys, the desired parameter can be selected and by pressing the P key again the display will alternate between the parameter code and its setting. The value of which can be changed with the UP and DOWN keys.

Once the desired value has been set, press the key P again: the new value will be memorized and the display will show only the abbreviation of the selected parameter.

Pressing the UP and DOWN keys, it is possible to select another parameter (if present) and change it as described above.

To select another group of parameters, keep the UP or the DOWN key pressed for about 1 second, after which the display will return to the parameter group heading.

Using the UP and DOWN keys it will be possible to select another group (if present).

To exit the programming mode, do not press any key for about 20 seconds, or keep the UP or DOWN key pressed until it exits the programming mode.

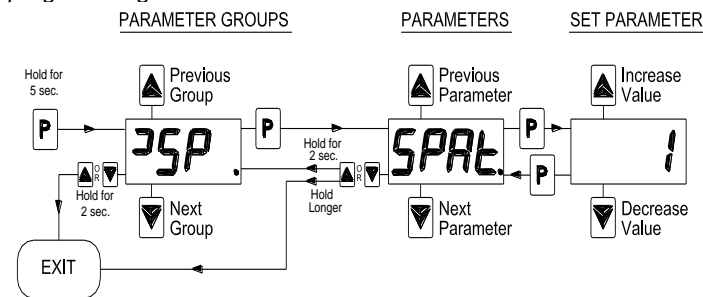

2.3 - PARAMETER PROTECTION USING THE PASSWORD

The instrument has a parameter protection function using a password that can be personalized, via the "PASS" parameter in the "PAN" group.

If one wishes to have this protection, set the password number desired in the parameter "PASS".

When password protection is enabled, press the P key to access the parameters and keep it pressed for about 5 seconds, after which the LED SET will flash and the display will show "0".

At this point, using the UP and DOWN keys, scroll to the password number programmed and press the "P" key.

If the password is correct, the display will show the code that identifies the first group of parameters ("SP") and it will be possible to program the instrument as described above.

Protection using a password can be disabled by setting the parameter "PASS" = OFF.

2.4 - PARAMETERS PROGRAMMING LEVELS

The instrument has two parameter programming levels.

The first level ("visible" parameters) is accessed using the procedure described above (with or without password) while the second level ("hidden" parameters) can be accessed using the following procedure:

Remove power from the instrument, press and hold the P key while returning power to the instrument.

After about 5 sec. the SET led will light up, the display will show the code that identifies the first group of parameters ("SP") and it will be possible to set the parameters of the instrument using the same programming procedure described above.

Once any parameter has been selected and the SET LED is on, it means that parameter can be programmed on the first level ("visible").

If the SET LED is off it means that parameter can only be programmed on this level (i.e. "hidden").

To change the visibility of parameters, press the U key: the led SET will change status, indicating the accessibility level of the parameter (on = parameter "visible"; off = parameter "hidden").

The procedure accessing "hidden" parameters allows the "PASS" parameter to be checked and changed, and is useful if the password value has been forgotten.

2.5 - ACTIVE SET POINT SELECTION

The instrument allows up to 2 different control Set points to be pre-set ("SP 1" and "SP 2") and to choose which one to make active. This function can be used if it is necessary to switch between two different function temperatures (e.g. day and night or positive and negative etc).

The active set point can be selected:

- Using the parameter "SPAt"
- using the key U if the parameter "USrb" = 3.
- Using the key DOWN/AUX if the parameter "Fbd" = 3.
- Using the digital input if the parameter. "diF" = 8 (see par. 4.10 e 4.12)

The Set points "SP1" and "SP2" can be set with a value between the programmed value in parameter. "SPLL" and the programmed value in parameter "SPHL".

Note: in the examples that follow, the Set point is generally indicated as "SP". When operating, the instrument will work according to which Set point is selected as active.

2.6 - ON / STAND-BY FUNCTION

The instrument, once powered up, can assume 2 different conditions:

- ON : means that the instrument is controlling the process.
 - STAND-BY : means that the instrument does not use any control function and the display is turned off except for the green SET led.
- If there is a loss of power and when power returns, the system always sets itself in the condition it was in before the outage.

The ON/Stand-by function can be selected:

- Using the key U if the parameter "USrb" = 4.
- Using the key DOWN/AUX if the parameter "Fbd" = 4.
- using the digital input if the parameter "diF" = 10 (see par. 4.10 e 4.12)

2.7 - TIME SETTING

When the instrument has an internal clock it is necessary to program it to the current time by using the parameter "StCL" contained in the group "CLO".

The instrument has an internal quartz clock; however, should the clock become inaccurate (especially over a long period) it can be adjusted daily using the parameter "CLOF" contained in the same group.

The operation of the clock will be powered by an internal capacitor for a period of about 4 hours with a loss of main power.

If the instrument should remain without power for a long period, remember to re-program the exact time.

3 - INFORMATION ON INSTALLATION AND USE



3.1 - PERMITTED USE

The instrument has been projected and manufactured as a measuring and control device to be used according to EN61010-1 for the altitudes operation to 2000 ms.

The use of the instrument for applications not expressly permitted by the above mentioned rule must adopt all the necessary protective measures.

The instrument CANNOT be used in dangerous environments (flammable or explosive) without adequate protection.

The installer must ensure that EMC rules are respected, also after the instrument installation, if necessary using proper filters.

Whenever a failure or a malfunction of the device may cause dangerous situations for persons, things or animals, please remember that the process has to be equipped with additional devices which will guarantee safety.

Whenever a failure or a malfunction of the device may cause dangerous situations for persons, things or animals, please

remember that the process has to be equipped with additional devices which will guarantee safety.

3.2 - MECHANICAL MOUNTING

The instrument, in the 33 x 75 mm enclosure, is designed for mounting flush to the panel.

Cut a hole 29 x 71 mm and insert the instrument, securing it with the special bracket provided.

We recommend that a gasket be used to obtain the IP 65 front protection rating.

Avoid placing the instrument in environments with very high humidity levels or dirt that may create condensation or introduction of conductive substances into the instrument.

Ensure adequate ventilation to the instrument and avoid installation in enclosures that house devices which may overheat or may cause the instrument to function at a temperature higher than our specifications allow.

Connect the instrument as far away as possible from sources of electromagnetic disturbances such as motors, power relays, relays, solenoid valves, etc.

3.3 - ELECTRICAL CONNECTION

Connect only one wire to each terminal, according to the following diagram, checking that the power supply is the same as that indicated on the instrument and that the current load through the outputs is no higher than the maximum current permitted in the specifications.

As the instrument is not equipped with either switches or internal devices to protect against overload of current: the installation must include an overload protection device and a two-phase circuit-breaker, placed as near as possible to the instrument, and located in a position that can easily be reached by the user and marked appropriately to shut off the power supply to the equipment.

It is also recommended that the supply of all the electrical circuits connected to the instrument be protected properly, using devices (ex. fuses) proportionate to the expected currents.

It is strongly recommended that cables with proper insulation be used according to the working voltages and temperatures.

Furthermore, the input cable of the process sensing probe has to be kept separate from line voltage wiring. If the input cable of the probe is screened, it has to be connected to the ground with only one side.

When the instrument is 12 V version, it's recommended to use an external transformer (model TCTR) or similar, and to use only one transformer for each instrument because there is no insulation between supply and input.

We recommend that the parameter settings be verified to make certain the desired values have been selected for the application before connecting the outputs to the process. This should be done to avoid a malfunction that could cause damage to people, things or animals.

ControlTec, Inc and its legal representatives do not assume any responsibility for any damage to people, things or animals deriving from violation, wrong or improper use or in non compliance with the instrument's features.

3.4 - ELECTRICAL WIRING DIAGRAM

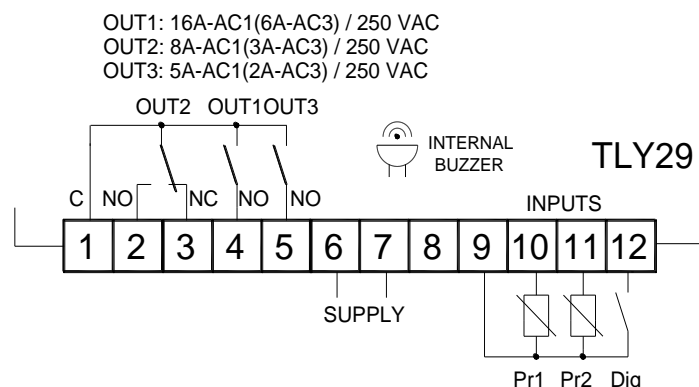

4 - FUNCTIONS

4.1 - MEASURING AND VISUALIZATION

All the parameters concerning process measuring are contained in the group **"^dInP"**.

Via the parameter **"SEnS"** it is possible to select the type of probes that one wishes to use. The only usable probes are thermistors PTC KTY81-121 (Ptc) or NTC 103AT-2 (ntc).

Once the type of probe has been selected, through the parameter **"Unit"**, it is possible to select the temperature unit of measurement (°C or °F) and, through the parameter **"dP"**, the resolution of the desired measurement (OFF=1°; On =0,1°).

The instrument allows the measurement to be calibrated or offset according to application needs, through the parameters **"OFS1"** (for the probe Pr1) and **"OFS2"** (for the probe Pr2).

If probe Pr2 (evaporator) is not used, set the parameter **"Pr 2" = OFF**.

Using the parameter **"FIL"**, it is possible to set the time constant for the software filter of measured input values. This reduces the sensitivity to measurement fluctuations smoothing the display value.

Through the parameter **"diSP"**, it is possible to choose the primary display indication. Choices include the cabinet probe (Pr 1), the evaporator probe (Pr 2), the set point value (SP), the current hour if the instrument has a clock (CLo) or the numerical display switched off (OFF).

Regardless of how the parameter **"diSP"** is set, it is possible to see all the variables in rotation by pressing the key **U**, the display will alternately show the code that identifies the variable (**Pr 1**, **Pr 2** and, if present the clock, **CLo**) and its current value.

The instrument automatically returns to the programmed display mode 15 seconds after the last press of the U key.

Please remember that display of the Pr1 probe temperature can be "masked" during defrosts by using the display block function parameter **"dLo"** (see par. 4.6).

4.2 - OUTPUTS CONFIGURATION

The instrument outputs can be configured in the parameter group **"^dOut"** where the relevant parameters **"O1F"**, **"O2F"**, **"O3F"** are found and also the parameter **"buF"** that allows configuration of the internal buzzer (if present).

The outputs can be configured for the following functions

= **Out** - to control the compressor or other temperature control device

= **dEF** - to control the defrosting device

= **FAn** - to control the fans

= **AuS** - to control the auxiliary device (see par. 4.11)

= **ALt** - to control a silenceable alarm device through a contact that is normally open, and then closed when the alarm sounds

= **AL** - to control an alarm that cannot be silenced through a contact that is normally open and closed when the alarm sounds.

= **ALL** - to control an alarm with a memory function through a contact that is normally open and closed when the alarm sounds.

= **-ALt** - to control a silenceable alarm device through a contact that is normally closed, and then open when the alarm sounds.

= **-AL** - control an alarm that cannot be silenced through a contact that is normally closed and open when the alarm sounds.

= **-ALL** - to control an alarm with a memory function through a contact that is normally closed and open when the alarm sounds (see alarm memory).

= **OFF** - Disabled output

4.3 - TEMPERATURE CONTROL

All the parameters concerning temperature control are contained in the group **"^drEG"**.

The control scheme of the instrument is ON/OFF and acts on the output configured as "Out" depending on the input value of probe Pr1, the active Set Point **"SP"** (1 or 2), the intervention differential **"HSEt"** and the function mode **"Func"**.

Depending on the function mode programmed on the parameter **"Func"** the differential is automatically configured by the control with

positive values for a Refrigeration control (**"Func"**=Cool) or with negative values for a heating control (**"Func"**=HEAt).

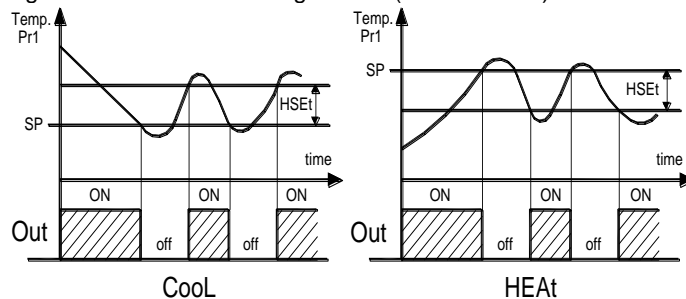

In the event of cabinet probe error (Pr1), it is possible to set the instrument so that the output "Out" continues to work in cycles according to the times programmed in the parameter **"tonE"** (activation time) and **"toFE"** (deactivation time).

If an error occurs on the Pr1 probe the instrument activates the output for the time "tonE", then deactivates it for the time "toFE" and so on while the error remains.

Programming **"tonE" = OFF** the output will remain switched off during a probe error condition.

Programming **"tonE"** to any value and **"toFE" = OFF** the output will remain switched on in probe error condition.

Remember that the temperature control function can be conditioned by the "Continuous Cycle", "Compressor Protection", "Minimum compressor function time", "Delay compressor start up after defrosting" and "inhibition of compressor close to defrosting" functions described below.

4.4 - CONTINUOUS CYCLE FUNCTION (BLAST CHILL)

The instrument has a continuous cycle (blast chill) function that makes it possible to keep the compressor output configured as "out" active for the time set in parameter **"tCC"** (in the group **"^drEG"**) regardless of the temperature control command.

The function can be used for example, when rapid lowering of the product temperature is required after the refrigerator loading phase. During the continuous cycle, the defrosting is inhibited and the temperature alarms are disabled during the entire cycle and later for the time set in parameter **"dALC"** (see par. 4.9).

Starting up a continuous cycle can only be done by a manual command using the U or DOWN/AUX (**"UrSb"** or **"Fbd" = 2**) keys or via the digital input (**"diF"=3**) if suitably programmed (see par. 4.10 and 4.12).

The continuous cycle in progress is shown on the display with the indication **CC** and can be stopped using the same keys mentioned above or digital input (as for activation).

The continuous cycle function cannot be activated during defrosting and with **"tCC" = OFF**.

4.5 - COMPRESSOR PROTECTION FUNCTION AND DELAY AT POWER-ON

The function "Compressor Protection" carried out by the controller aims to avoid "short starts" of the compressor controlled by the instrument in cooling applications.

This function allows a time buffer for switching of the "OUT" output associated with a temperature regulation request.

The protection consists of preventing the output from being switched on during the time set in the parameter **"PtC"** depending on how parameter **"PSC"** has been programmed.

Activation occurs only after the "PtC" time has elapsed.

During the power on delay phase, if the request for cooling is no longer needed for any reason the switching of the output is cancelled.

Using the parameter **"PSC"**, it is possible to set the type of compressor protection required and therefore when the inhibition time **"PtC"** must start.

The parameter **"PSC"** can be set as:

= 1: Power on delay

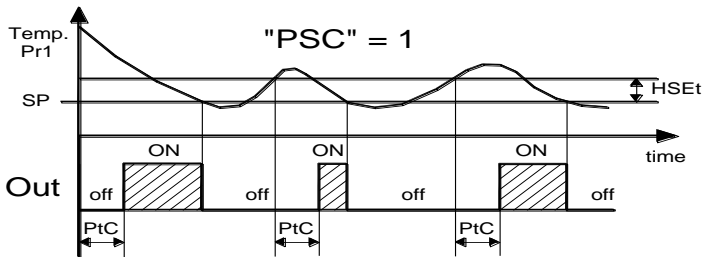

= 2: Delay after power off

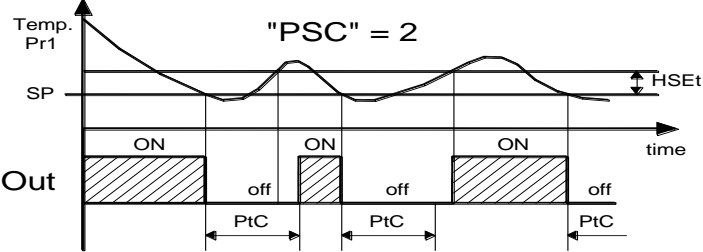

= 3: Delay between power on phases.

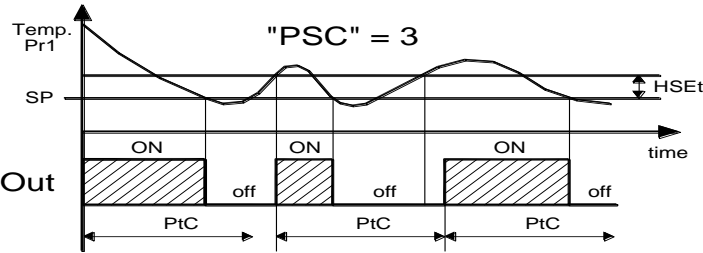

The function is disabled by programming "PtC" = 0.

Through the parameter "Lct" it is possible to set the minimum activation time of the output to avoid short starting the compressor. During the power on delay phases the led OUT flashes.

It is also possible to prevent switching of the output after the instrument is first turned on for the time set in the parameter "od". The function is disabled by "od" = OFF. During the power on delay phase, the display indicates **od**, alternating with the normal display of temperature.

4.6 - DEFROST CONTROL

All the parameters concerning the defrosting control that act on the outputs configured as "Out" and "dEF", are contained in the "dEF" group.

The type of defrosting the instrument carries out is set by the parameter "dtyP" and can be programmed as follows:

= **EL** - WITH ELECTRICAL HEATING or BY STOPPING COMPRESSOR (during defrosting, the output "Out" is deactivated while the output "dEF" is enabled)

= **in** - WITH HOT GAS or REVERSE CYCLE (during defrosting the outputs "Out" and "dEF" are enabled)

The automatic defrosting can take place at intervals or if the instrument has an internal clock, at set hours.

Defrosting at intervals is possible by setting the time that runs between the two next automatic defrost cycles in the parameter "dint".

Counting this interval is set through the parameter "dCt" that can be programmed as follows:

= **rt** - counts the total function time (instrument on)

= **ct** - counts only the compressor function time (output OUT switched on)

= **cS** - the instrument carries out a defrosting cycle at each compressor stop (i.e. at each deactivation of the output OUT). If this option is used, set "dint"=OFF.

If the instrument has an internal clock, it is possible to carry out up to 6 defrost cycles per day at set times.

To use this mode, it is necessary to set the parameter "dint"=OFF so that the defrosting at intervals is disabled and to set the parameters "dF 1", "dF 2", "dF 3", "dF 4", "dF 5", "dF 6" with the times when the defrosting must be carried out.

The automatic defrosting cycle can be at time intervals or, if an evaporator probe is used (Pr2), when a temperature is reached.

If the evaporator probe is not used (par. "Pr 2" = OFF) the duration cycle is set by the parameter "dEFE".

If the evaporator probe is used (parameter "Pr 2" = on) the defrosting takes place when the temperature measured by the probe exceeds the temperature set in the parameter "tEdF".

If this temperature is not reached in the time set in the parameter "dEFE", defrosting does not take place..

In order to avoid unnecessary defrosting the parameter "tSdF" is used to set the enablement temperature for defrosting

If the temperature measured by the probe is higher than the one set in the parameter "tSdF" and in the parameter "tEFE" the defrosting is inhibited.

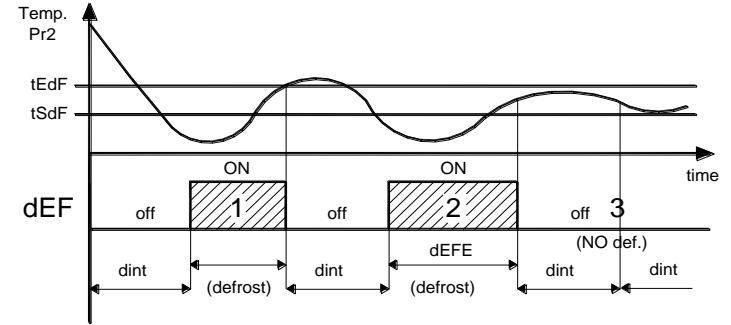

Examples: defrosting 1 ends due to reaching the set temperature "tEdF", defrosting 2 ends at the end of the "dEFE" time as the temperature "tEdF" is not reached, defrosting 3 does not take place as the temperature is higher than "tSdF".

At the end of defrosting, it is possible to delay the start of the compressor (output "Out") for the time set in parameter "tdCO" to allow the evaporator to drain.

During this delay, the led Def flashes to indicate the draining state. It is also possible to prevent starting the compressor when a defrost cycle is close to starting to avoid wasting energy.

If within the time set in the parameter "COFd" an activation request for the compressor "Out" should take place, the output will not switch and the Out led will flash.

If one wishes to set a defrosting cycle every time the instrument is turned on (as long as the conditions set in the parameters "tSdF" and "tEFE" apply) program the parameter "SdEF" = YES.

This allows the evaporator to be permanently defrosted, even when frequent interruptions to power supply occur that may cause the cancellation of the various defrosting cycles.

During defrosting, the temperature measured by the cabinet probe (Pr1) may increase excessively (this obviously depends on the position of the Pr1 probe compared to the evaporator).

In the event that one does not wish this increased temperature to be displayed by the instrument, it is possible to use "dLo" (Block display during defrosting) parameter and "Etdu" (Differential unblocking of display after defrosting).

The parameter "dLo" = On allows the last Pr1 temperature reading to be held during the defrosting cycle until the temperature returns under the value ["SP" + "Etdu"] after defrosting or the time set in the parameter "dALd" contained in the block "AL".

With "dLo" = Lb, this will display **dEF** during defrosting and at the end of defrosting will display **PdEF** until the temperature sensed on Pr1 returns below the value ["SP" + "Etdu"] or the time set on the parameter "dALd" contained in the block "AL".

Alternatively with the "dLo" = OFF, the instrument will continue to display the temperature measured by the Pr1 probe during defrosting.

Note that during defrosting, the temperature alarms are disabled during the entire cycle and afterwards for the time set in the parameter "dALd" (see par. 4.9).

4.7 - MANUAL DEFROST

To start a manual defrost cycle, press and hold the UP/DEFROST key (when not in programming mode) for about 5 seconds after which, if the conditions are correct, the led DEF will light up and the instrument will carry out a defrosting cycle.

The start up or switch off commands of a defrosting cycle can also be initiated by the digital input when correctly programmed (see par. 4.10).

4.8 - EVAPORATOR FANS CONTROL

All the parameters concerning fan control are contained in the "FAn" group.

The control of the fans on the output configured as "FAn" depends on the control status of the instrument and the temperature measured by the Pr2 probe.

In the case that the Pr2 probe is not used (parameter "Pr 2" = OFF) or in error (E2 o -E2), the output FAN is only activated depending on the parameters "FCOF" and "FEdF".

The parameter "FCOF" decides whether the fans must always be switched on independently of the compressor status ("FCOF"=On) or be switched off together with the compressor ("FCOF"=OFF).

The parameter "FEdF" decides whether the fans must always be switched on independently of the defrosting status ("FEdF"=On) or switched off during defrosting ("FEdF"=OFF).

In this latter case, it is possible to delay the start up of the fans even after the end of the defrosting of the time set in the parameter "Fd".

It is possible to disable the fans when the temperature measured by the Pr2 probe is higher than the setting in parameter "FLt" (temperature too hot) or when it is lower than the setting in the parameter "Fct" (temperature too cold).

The relative differential that can be set in parameter "dF" is also associated with these parameters.

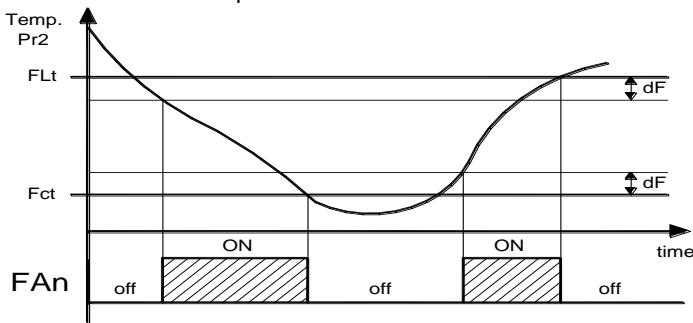

4.9 - ALARM FUNCTIONS

All the parameters concerning the alarm functions are contained in "AL" group.

The alarm functions of the instrument are signalled via the internal buzzer, if present and configured with parameter "buF". The output desired must be selected and is effected by configuration of the parameters "O1F", "O2F" or "O3F".

The possible selections of these parameters for the alarm signalling function are:

= **ALt** - when one wants the buzzer or output to be activated in alarm and can be disabled (alarm silencing) manually by pressing any key of the instrument (typical application for sound signal).

= **AL** - when one wants the buzzer or output to be activated in alarm status but cannot be disabled manually and are therefore only disabled when the alarm status ceases (typical application for a light signal).

= **ALL** - when one wants the buzzer or output to be activated in alarm status and that they remain activated even when the alarm has ceased (see par.4.9.4) Disablement (recognition of memorized alarm) can only be carried out manually by pressing any key when the alarm has ended (typical application for light signal).

= **-ALt** - when one wants the function described as ALt but with an inverse function (buzzer or output activated in normal condition and disabled in alarm status).

= **-AL** - when one wants the function described as AL but with inverse logic (buzzer or output activated in normal conditions and disabled in alarm status).

= **-ALL** - when one wants the function described as ALL but with inverse working logic (buzzer or output activated in normal conditions and disabled in alarm status).

When no alarms are present, the green LED OK is lit.

Any active alarm is shown on the instrument display with the lighting of the AL LED and switching off of the OK LED.

Any silenced or memorized alarm status is shown by the flashing AL LED.

The alarm conditions of the instrument are:

- Probe errors "E1", "-E1", "E2", "-E2"
- Temperature alarms "HI" and "LO"
- External alarms "AL"
- Open door alarm "AP"

4.9.1 - TEMPERATURE ALARMS

The temperature alarms work based on the Pr1 probe measurements, the type of alarm set in the "Aty" parameter the alarm thresholds set in parameters "HAL" (maximum alarm) and "LAL" (minimum alarm) and the relative differential "dAL".

Through the parameter "Aty" it is possible to set the alarm thresholds "HAL" and "LAL" which must be set as either absolute ("Aty"=Ab) or relative to the active Set Point ("Aty"=dE).

Using certain parameters it is also possible to cancel or delay the actuation of these alarms when certain conditions are present.

These parameters are:

"PAL" - is the temperature alarm exclusion time after powering on the instrument if the instrument happens to be in alarm status when it is powered up.

"dALd" - is the temperature alarm exclusion time at the end of defrosting (and, if programmed, at the end of draining)

"dALc" - is the temperature alarm exclusion time at the end of a continuous cycle (blast chill).

"ALd" - is the temperature alarm delay activation time

The temperature alarm is enabled at the end of exclusion time and is enabled after the "ALd" time when the temperature measured by the Pr1 probe exceeds or goes below the respective maximum and minimum alarm thresholds.

The alarm thresholds will be the same as those set on the parameters "HAL" and "LAL" if the alarms are absolute ("Aty"=Ab)

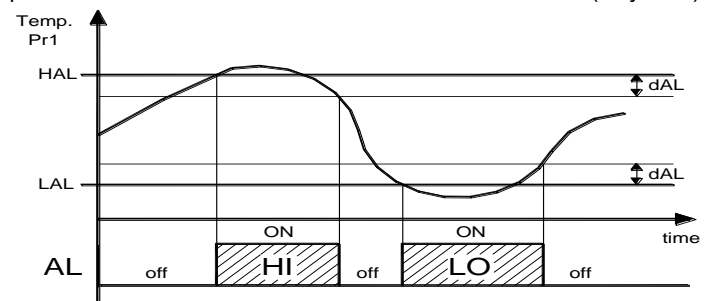

Or will be the values ["SP"+"HAL"] and ["SP"-LAL"] if the alarms are relative ("Aty"=dE).

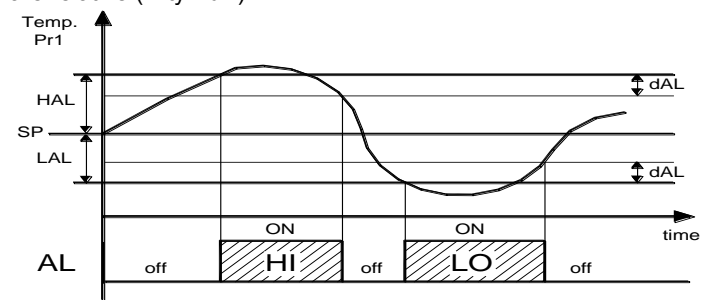

The maximum and minimum temperature alarms can be disabled by setting the parameters "HAL" and "LAL" = OFF.

The following happens when the instrument goes into an alarm: the alarm buzzer and/or output will trip, the instrument signals the alarm by turning on the led light AL, switching off the LED OK. Also, the led - is turned on in case of minimum alarm or the led + for maximum alarm, and the display will flash the following:

- Alternately **HI** and the set variable of "diSP" parameter for maximum alarm

- Alternately **LO** and the set variable of "diSP" parameter for the minimum alarm

4.9.2 - EXTERNAL ALARM

The instrument can signal an external alarm by activating the digital input with the function programmed as "diF" = 4 or 9 (see par. 4.10).

As the alarm (buzzer and/or output) is active, the instrument displays the alarm by turning on the led AL, turning off the led OK and alternating **AL** and the variable set in parameter "diSP" on the display.

4.9.3 - OPEN DOOR ALARM

The instrument can signal an open door alarm by activating the digital input with the function programmed as "din" = 5 or 6 (see par. 4.10).

When the digital input is activated and after the delay programmed in parameter "oAd", the instrument signals the alarm via the buzzer and/or output, the AL led is illuminated, the OK led is turned off and **AP** and the variable set in parameter "diSP" are shown alternating on the display.

4.9.4 - ALARM MEMORY

The instrument offers the possibility of enabling the alarm memory function via the "tAL" parameter.

If "tAL" = no, the instrument cancels the alarm signal when the alarm status ends, if it is programmed as "yES", the led AL flashes even when the alarm status has ended to indicate that there has been an alarm.

If the memorized alarm is for temperature, it also keeps the led - flashing to show a minimum alarm and + to show a maximum alarm has occurred.

To cancel the alarm memory signal, press any key.

Please note that if an output function is desired (or the buzzer) with the alarm memory (=ALL or =-ALL) it is necessary to set the "tAL" parameter = yES.

4.10 - DIGITAL INPUT

All the parameters concerning the digital input functions are contained in the "din" group.

The digital input present on the instrument accepts voltage free contacts. The function carried out is defined by the "diF" parameter and the action can be delayed for the time set in parameter "did".

The parameter "diF" can be configured for the following functions:

= **0** - Digital input not active

= **1** - defrosting commencement command with contact normally open: on closing the input (and after the "did" time) a defrosting cycle is activated.

= **2** - defrosting end command with contact normally open: on closing the input (and after the "did" time) a defrosting cycle is ended if in progress or defrosting is inhibited.

= **3** - continuous cycle activation command with contact normally open: on closing the input (and after the "did" time) a continuous cycle is started as described in the paragraph on the continuous cycle function (blast chill).

= **4** - External alarm signal with contact normally open: on closing the input (and after the "did" time) the alarm is activated and the instrument alternately displays **AL** and the variable set in "diSP".

= **5** - Cabinet door opening with fan block with contact normally open: on closing the input (and after the "did" time) the fans are stopped and the instrument alternates **AP** and the variable set in "diSP" parameter on the display. With this function mode, the action of the digital input also activates the time that can be set in parameter "oAd". After that time, the alarm is activated to signal that the door has been left open.

= **6** - Cabinet door opening with compressor and fan block with contact normally open: similar to "diF" = 5 but with fan and compressor block.

= **7** - Remote control of auxiliary output AUX with contact normally open: on closing the input (and after the "did" time) the auxiliary

output is activated as described in the "FOA" = 2 function mode of the auxiliary output.

= **8** - Selecting the active set point with contact normally open: on closing the input (and after the "did" time) the temperature control set point "SP 2" is activated. If the input is open the "SP 1" set point is active (see selecting active set point)

= **9** - Signalling of external alarm with disablement of all the control outputs with contact normally open: on closing the input (and after the "did" time) all the control outputs are disabled, the alarm is activated and the instrument alternates **AL** and the variable set in "diSP" parameter on the display.

= **10** - Switching on/switching off (Stand-by) of instrument with contact normally open: on closing the input (and after the "did" time) the instrument is switched on while it is placed in Stand-by when opened.

= **-1** - defrosting start command with contact normally closed: similar to "diF"=1 but with function logic reversed.

= **-2** - defrosting end command with contact normally closed: similar to "diF"=2 but with function logic reversed.

= **-3** - continuous cycle (blast chill) start-up command with contact normally closed: similar to "diF"=3 but with function logic reversed.

= **-4** - External alarm signal with contact normally closed : similar to "diF"=4 but with function logic reversed.

= **-5** - Cabinet door opening with fan block with contact normally closed : similar to "diF"=5 but with function logic reversed

= **-6** - Cabinet door opening with compressor and fan block with contact normally closed : similar to "diF"=6 but with function logic reversed.

= **-7** - Remote control of auxiliary output AUX with contact normally closed : similar to "diF"=7 but with function logic reversed.

= **-8** - Selecting the active set point with contact normally closed: similar to "diF"=8 but with function logic reversed.

= **-9** - Signalling of external alarm with disablement of all the outputs with contact normally closed: similar to "diF"=9 but with function logic reversed

= **-10** - Switching on/off (Stand-by) of instrument: similar to "diF"=10 but with function logic reversed.

4.11 - AUXILIARY OUTPUT

All the parameters concerning the auxiliary output functions are contained in the "AuS" group.

The auxiliary output can be configured to operate using any of the available outputs by programming the parameter of the desired output = AuS.

The function carried out is defined by the "FOA" parameter and the function is regulated by the time set in the "tuA" parameter.

The parameter "FOA" can be configured for the following functions:

= **0** - Auxiliary output not active

= **1** - Regulation output delayed with contact normally open: the auxiliary output is activated with delay that can be set on the parameter "tuA" compared to the output configured as Out. The output is then turned off at the same time as the OUT output is disabled. This function mode can be used as a command for a second compressor or for any other component according to the same OUT output conditions, but will be delayed after the start up of the compressor to avoid excess electricity draw.

= **2** - Activation by front key (U or DOWN/AUX) or by digital input with contact normally open: the output is activated by pressing the U or DOWN/AUX keys if configured ("USrb" or "Fbd" = 1) or via activation of the digital input if configured ("diF"=7). These commands have a bi-stable function, which means that when first pressed, the output key is activated and with a second press it is disabled. In this mode, the AUX output can be turned off automatically after a certain time that is set in the "tuA" parameter. With "tuA" = OFF the output is activated and deactivated only manually, using the front U or DOWN/AUX key or via the digital input. The output, once activated, is turned off automatically after the set time. This function can be used, for example, as a cabinet light command, for controlling glass condensation heaters or other utilities.

= -1 - Delayed control output with contact normally closed: similar to "FOA"=1 but with function logic reversed.

= -2 - Activation by front U or DOWN/AUX key or by digital input with contact normally closed: similar to "FOA"=2 but with function logic reversed.

4.12 - FUNCTIONING OF KEYS "U" AND "DOWN/AUX"

Two of the instrument keys, in addition to their normal functions, can be configured to operate other commands.

The U key function can be defined by the parameter "USrb" while the DOWN/AUX key function can be defined by the parameter "Fbd" both contained in the group "lPAn".

Both the parameters have the same capabilities and can be configured for the following functions:

= 0 - The key carries out no function.

= 1 - Pressing the key for at least 1 second, it is possible to enable/disable the auxiliary output if configured ("FOA"=2).

= 2 - Pressing the key for at least 1 second, it is possible to enable/disable a continuous cycle (see continuous cycle function).

= 3 - Pressing the key for at least 1 second, it is possible to select one of the 2 memorised set point in rotation. Once selection has been made, the display will flash the active set point code for about 1 sec. (SP 1 or SP 2).

= 4 - Pressing the key for at least 1 second, it is possible to switch the instrument from the ON status to Stand-by status and vice versa.

4.13 - PARAMETERS CONFIGURATION BY "KEY01"

The instrument is equipped with a connector that allows functioning parameters to be transferred to and from the instrument using the KEY01 device with 5 pole connector.

This device it's used for rapid programming of multiple instruments that need to have the same configuration parameters.

To use the KEY01 device it's necessary that either the device or instrument is supplied with a power source.

Instrument powered and device not powered

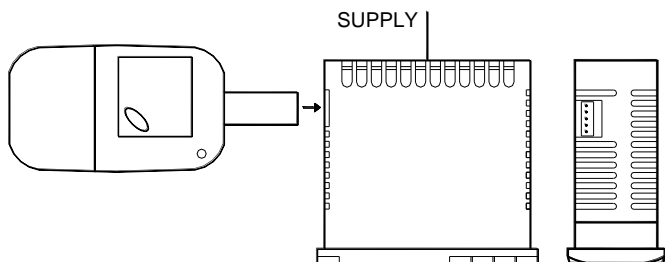

Instrument powered from the device

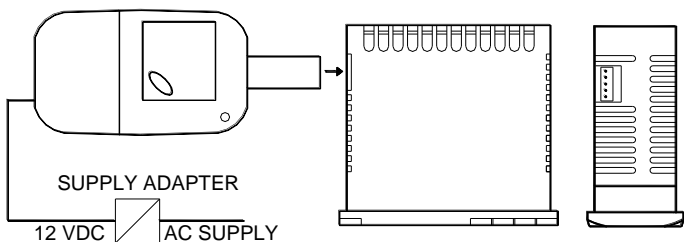

To transfer the configuration of an instrument into the device (UPLOAD) it is necessary to do the following:

- 1) Position both dip switches of KEY 01 in the OFF mode.
- 2) Connect the device to the TLY's serial connection port.
- 3) Verify that the instrument or the device have power.
- 4) Observe the indication led on the KEY 01 device: if it is green this means that a configuration is already loaded on the device. If it is blinking green or red this means that no configuration has been loaded.
- 5) Press the button on the device.
- 6) Observe the indication led: after pressing the button, the led will turn red. At the end of the data transfer, it will change to green.
- 7) It is now possible to disconnect the device.

To transfer the configuration loaded on the device into an instrument of the same family (DOWNLOAD), it is necessary to do the following:

- 1) Position both dip switches of KEY 01 in the ON mode.
- 2) Connect the device to a TLY having the same features as the one used to originally program the KEY01.
- 3) Verify that the instrument or the device have power.
- 4) Observe the indication led on the device: it must show a steady green light. If the led blinks green or red, there are no valid configurations loaded on the device.
- 5) If the led shows a steady green, press the button on the device.
- 6) Observe the indication led: after pressing the button, the led will turn red. At the end of the data transfer, it will change to green.

5 - PROGRAMMABLE PARAMETERS TABLE

Below is a description of all the parameters available on the instrument. Some of them may not be present, depending on the type of instrument or because they are automatically disabled and unnecessary based on other settings previously made.

¹SP Group (parameters relative to Set Point)

Par.	Description	Range	Def.	Note
1	SPAt	Active Set point	1 ÷ 2	1
2	SP1	Set Point 1	SPLL ÷ SPHL	0.0
3	SP2	Set Point 2	SPLL ÷ SPHL	0.0
4	SPLL	Minimum Set Point	-58 ÷ SPHL	-50.0
5	SPHL	Maximum Set Point	SPLL ÷ 302	100.0

¹InP Group (parameters relative to measuring inputs)

Par.	Description	Range	Def.	Note
6	SEnS	Probes Type	Ptc - ntc	Ptc
7	OFS1	Pr1 Probe (cell) Calibration	-30 ÷ 30 °C/°F	0.0
8	OFS2	Pr2 Probe (evaporator) Calibration	-30 ÷ 30 °C/°F	0.0
9	Pr 2	Pr2 Probe Presence (evaporator)	On - OFF	On
10	Unit	Unit of measurement	°C - °F	°C
11	dP	Decimal point	On - OFF	On
12	FiL	Measurement filter	OFF ÷ 20.0 sec	2.0
13	diSP	Variable visualized normally on display: OFF=Display off Pr1= measurement probe Pr1 Pr2= measurement probe Pr2 SP= Active Set Point CL= Clock time	OFF - Pr1 - Pr2 - SP - CL	Pr1

¹rEG Group (parameters relative to temperature control)

Par.	Description	Range	Def.	Note
14	HSEt	Differential	0 ÷ 30 °C/°F	2.0
15	tonE	Activation time output OUT for probe Pr1 broken	OFF ÷ 99.59 min.sec	OFF
16	toFE	Deactivation time output OUT for probe Pr1 broken	OFF ÷ 99.59 min.sec	OFF
17	Func	Function mode output OUT	HEAt - Cool	Cool
18	tCC	Continuous cycle Time	OFF ÷ 99.59 hrs.min	OFF

¹**dEF Group** (parameters relative to defrosting control)

Par.	Description	Range	Def.	Note
19	dtyP Defrosting Type: EL = electrical in = hot gas/reverse cycle	EL - in	EL	
20	dint Defrosting interval	OFF ÷ 99.59 hrs.min	6.00	
21	dF 1 Time start defrost 1	OFF - 00.00 ÷ 23.59 hrs.min	OFF	
22	dF 2 Time start defrost 2	OFF - 00.00 ÷ 23.59 hrs.min	OFF	
23	dF 3 Time start defrost 3	OFF - 00.00 ÷ 23.59 hrs.min	OFF	
24	dF 4 Time start defrost 4	OFF - 00.00 ÷ 23.59 hrs.min	OFF	
25	dF 5 Time start defrost 5	OFF - 00.00 ÷ 23.59 hrs.min	OFF	
26	dF 6 Time start defrost 6	OFF - 00.00 ÷ 23.59 hrs.min	OFF	
27	dEFE Max. length of defrost cycle	0.01 ÷ 99.59 min.sec	30.00	
28	tEdF Defrost stop temperature	- 58 ÷ 302 °C/°F	8.0	
29	tSdF Defrost enable temperature	- 58 ÷ 302 °C/°F	2.0	
30	dCt Defrosting intervals Counting mode: rt = real time ct = On OUT time cS = defrost every off OUT	rt - ct - cS	rt	
31	tdCO Compressor delay after defrost (drainage time)	OFF ÷ 99.59 min.sec	OFF	
32	SdEF Defrost at power on	no - yES	no	
33	dLo Defrost display Lock OFF= display free On= Lock on temperature Pr1 before defrost Lb= Lock on label "dEF" (during defrosting) and "PdEF" (during post-defrosting)	On - OFF - Lb	OFF	
34	EtdU Differential display unlock after defrost	0 ÷ 30 °C/°F	2.0	
35	COFd Time compressor off before defrost	OFF ÷ 99.59 min.sec	OFF	

¹**FAn Group** (parameters relative to evaporator fan control)

Par.	Description	Range	Def.	Note
36	FCOF Fan status with compressor off	On - OFF	On	
37	FEdF Fan status during defrost	On - OFF	OFF	
38	FLt High temperature fan off	- 58 ÷ 302 °C/°F	2.0	
39	Fct Low temperature fan off	- 58 ÷ 302 °C/°F	-50.0	
40	dF Differential fan control	0 ÷ 30 °C/°F	2.0	
41	Fd Fan delay after defrost	OFF ÷ 99.59 min.sec	OFF	

¹**PrC Group**

(parameters relative to compressor protection and power on delay)

Par.	Description	Range	Def.	Note
42	PSC Type of compressor protection: 1= delay at switch on 2= delay after switch off 3= delay between starts	1 - 2 - 3	1	
43	PtC Compressor protection time	OFF ÷ 99.59 min.sec	OFF	
44	LtC Minimum compressor function time	OFF ÷ 99.59 min.sec	OFF	
45	od Delay at power on	OFF ÷ 99.59 min.sec	OFF	

¹**AL Group** (parameters relative to alarms)

Par.	Description	Range	Def.	Note
46	Aty Temperature alarms Type: Ab = Absolute dE =Relative to Set	Ab - dE	Ab	
47	HAL High temperature Alarm threshold	OFF / - 58 ÷ 302 °C/°F	OFF	
48	LAL Low temperature Alarm threshold	OFF / - 58 ÷ 302 °C/°F	OFF	
49	dAL Temperature Alarms Differential	0 ÷ 30 °C/°F	2.0	
50	ALd Temperature Alarms delay	OFF ÷ 99.59 min.sec	OFF	
51	tAL Alarm memory	no - yES	no	
52	PAL Temperature Alarms delay at power on	OFF ÷ 99.59 hrs.min	2.00	
53	dALd Temperature Alarms delay and unlock display delay after defrost	OFF ÷ 99.59 hrs.min	1.00	
54	dALc Temperature alarms delay after continuous cycle	OFF ÷ 99.59 hrs.min	OFF	
55	oAd Alarm delay with open door	OFF ÷ 99.59 min.sec	OFF	

¹**din Group** (parameters relative to digital input)

Par.	Description	Range	Def.	Note
56	diF Function and function logic of digital input: 0 = No function 1= Start defrost 2= End defrost 3= Continuous cycle 4= External alarm 5= Door open with fan block 6= Door open with fan and compressor block 7= Auxiliary output command 8= Selection of active Set Point 9= External alarm with deactivation of control outputs 10= Switch on/Switch off (Stand-by)	-10 / -9 / -8 / -7 / -6 / -5 / -4 / -3 / -2 / -1 / 0 / 1 / 2 / 3 / 4 / 5 / 6 / 7 / 8 / 9 / 10	0	
57	did Delay in acquiring digital input	OFF ÷ 99.59 min.sec	OFF	

6 - PROBLEMS, MAINTENANCE AND GUARANTEE

¹AuS Group (parameters relative to auxiliary output)

Par.	Description	Range	Def.	Note
58	FOA Function mode auxiliary output: 0= No Function 1= regulation output delayed 2= manual activation by key or digital input.	0 / 1 / 2 / -1 / -2	0	
59	tuA Time relative to auxiliary output	OFF ÷ 99.59 min.sec	OFF	

¹Out Group (parameters relative to configuration of outputs)

Par.	Description	Range	Def.	Note
60	Out1 Configuration of output function OUT1: OFF= No function Out= Temperature control (compressor) dEF= defrosting FAn= fans AuS= Auxiliary ALt= Silenceable alarm AL= Alarm not silenceable ALL= memoried alarm	OFF/Out/dEF/ FAn/AuS/ALt/ AL/ALL/ -ALt/ -AL/ -ALL	Out	
61	Out2 Configuration of output function OUT2: see "Out1"	OFF/Out/dEF/ FAn/AuS/ALt/ AL/ALL/ -ALt/ -AL/ -ALL	dEF	
62	Out3 Configuration of output function OUT3: see "Out1"	OFF/Out/dEF/ FAn/AuS/ALt/ AL/ALL/ -ALt/ -AL/ -ALL	FAn	
63	buF Configuration Buzzer function: see "Out1"	OFF/Out/dEF/ FAn/AuS/ALt/ AL/ALL/ -ALt/ -AL/ -ALL	ALt	

¹PAn Group (parameters relative to configuration of the keyboard)

Par.	Description	Range	Def.	Note
64	Fbd Function mode key DOWN/AUX: OFF= No function 1= Auxiliary output command 2= Continuous cycle command 3= Selection of active Set Point 4= Switch on/Switch off (Stand-by)	OFF / 1 / 2 / 3 / 4	OFF	
65	USrb Function mode key U: see "Fbd"	OFF / 1 / 2 / 3 / 4	OFF	
66	PASS Access Password to parameter functions	OFF ÷ 9999	OFF	

¹CLO Group (parameters relative to the internal clock)

Par.	Description	Range	Def.	Note
67	StCL Current time	0.00 ÷ 23.59 hrs.min	0.00	
68	CLOF Daily calibration of clock	-20 ÷ 20 sec	0	

6.1 - SIGNALLING

Error Signalling:

Error	Reason	Action
E1 -E1	The probe Pr1 may be interrupted or in short circuit, or may measure a value outside the range allowed	Check the correct connection of the probe with the instrument and check the probe works correctly
E2 -E2	The probe Pr2 may be interrupted or in short circuit, or may measure a value outside the range allowed	
EEPr	Internal memory error	Check and re-program if necessary

In Cell probe error status, the output OUT behaves as set by the parameters "tonE" and "toFE".

Other Signalling:

Message	Reason
od	Delay in switching on in progress
dEF	Defrosting in progress with "dLo"=Lb
PdEF	Post-defrosting in progress with "dLo"=Lb
CC	Continuous cycle in progress
HI	Maximum temperature alarm in progress
LO	Minimum temperature alarm in progress
AL	Digital input alarm in progress
AP	Door open

6.2 - CLEANING

We recommend cleaning the instrument with a slightly wet cloth using water. Do not use abrasive cleaners or solvents which may damage the instrument

6.3 - GUARANTEE AND REPAIRS

The instrument is under warranty against manufacturing flaws or faulty material within 12 months from delivery date.

The guarantee is limited to repairs or to the replacement of the instrument.

The eventual opening of the housing, the violation of the instrument or the improper use and installation of the product will bring about the immediate withdrawal of the warranty's effects.

In the event of a faulty instrument, either within the period of warranty, or further to its expiry, please contact our sales department to obtain authorization for sending the instrument to our company.

The faulty product must be shipped to CONTROLTEC with a detailed description of the faults found, without any fees or charge for ControlTec, except in the event of alternative agreements.

7 - TECHNICAL DATA

7.1 - ELECTRICAL DATA

Power supply: 12 VAC/VDC, 24 VAC/VDC, 100..240 VAC +/- 10%

Frequency AC: 50/60 Hz

Power consumption: 3 VA approx.

Input/s: 2 inputs for temperature probes: PTC (KTY 81-121, 990 Ω @ 25 °C) or NTC (103AT-2, 10KΩ @ 25 °C); 1 digital input for free voltage contacts

Output/s: 3 relay outputs: OUT1 SPST-NO (16A-AC1, 6A-AC3 250 VAC), OUT2 SPDT (8A-AC1, 3A-AC3 250 VAC), and OUT3 SPST-NO (5A-AC1, 2A-AC3 250 VAC). 16 A Max. for common (pin. 1)

Electrical life for relay outputs: 100000 operat. (VDE om.)

Installation category: II

Measurement category: I

Protection class against electric shock: Class II for Front panel

Insulation: Reinforced insulation between the low voltage part (supply H type and relay outputs) and front panel; Reinforced insulation between the low voltage section (supply type H and relay outputs) and the extra low voltage section (inputs); Reinforced between supply and relay outputs; No insulation between supply F type and inputs.

7.2 - MECHANICAL DATA

Housing: Self-extinguishing plastic, UL 94 V0

Dimensions: 33 x 75 mm, depth 64 mm

Weight: 115 g approx.

Mounting: Flush in panel in 29 x 71 mm hole

Connections: 2,5 mm² screw terminals block

Degree of front panel protection : IP 65 mounted in panel with gasket

Pollution situation: 2

Operating temperature: 0 ... 50 °C

Operating humidity: 30 ... 95 RH% without condensation

Storage temperature: -10 ... +60 °C

7.3 – MECHANICAL DIMENSIONS,

PANEL CUT-OUT AND MOUNTING [mm]

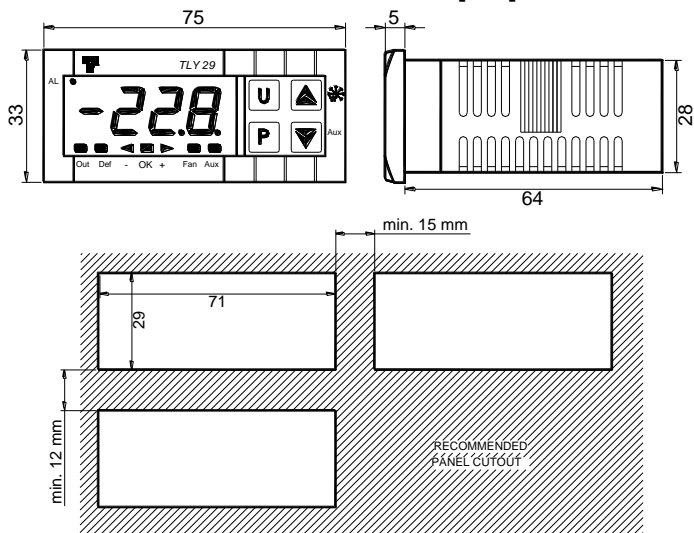

7.4 – FUNCTIONAL FEATURES

Temperature Control: ON/OFF mode

Defrost control: interval cycles or at programmed times (Real Time Clock Defrosting) by Electric Heating or hot-gas / reverse cycle

Measurement range: PTC: -50...150 °C / -58 ... 302 °F;

NTC: -50...109 °C / -58...228 °F

Display resolution: 1 ° or 0,1°

Overall accuracy: +/- 0,5 % fs

Sampling rate: 130 ms.

Display: 4 Digit Red h 12 mm

Endurance time of the internal clock without power supply: 4 hours approx. by internal condenser

Compliance: ECC directive EMC 89/336 (EN 61326), ECC directive LV 73/23 and 93/68 (EN 61010-1)

7.5 - INSTRUMENT ORDERING CODE

TLY 29 a b c

a : POWER SUPPLY

H = 100...240 VAC

L = 24 VAC/VDC

F = 12 VAC/VDC

b : INTERNAL BUZZER

B = Yes

- = No

c : REAL TIME CLOCK DEFROSTING

C = Yes

- = No